



# Model 2411/2412



Doc: CH-2411/02

Nov 2007

## Air operated heavy duty stainless steel ball valve with kit

2 way reduced bore heavy duty 3 piece stainless steel ball valve, ends BSP, designed for automation with integrally cast ISO5211 actuator mounting platform, fitted via stainless steel mounting kit with CH-air 'A' type pneumatic actuator. Supplied assembled and dry bench function tested. A minimum of 80 psi (5.5 bar) air supply pressure to the actuator is required.

2411 With double acting actuator

2412 With spring return actuator

Size range 1/4" to 4" (Butt & socket weld end options)

### Applications:

Water, low pressure steam, oil, air and most solvents and alkalis, subject to compatibility with wetted parts in contact with media. Actuators sized on a maximum differential pressure of 10 bar wet service, if the intended duty is above this differential, or dry (air or gas) call to check actuator sizing as a larger output actuator may be required.

Maximum working temperature of valve & actuator assembly is +130C. If the intended duty is at a higher temperature than this, contact us for options.

### Valve Specifications:

Body	CF8M Cast 316SS
Ball	CF8M Cast 316SS
Seats	Carbon filled PTFE
Pressure rating	UTI 2" 64 bar, rest 50 bar
Valve temp limits	-20 to +200°C
Actuator temp limits	-20 to + 70°C

### Accessories:

#### Solenoid control:

This provides electrical control of the valve. The air is constantly supplied to the solenoid which in turn controls the air to and from the actuator. The solenoid direct mounts to the actuator using the actuator's Namur connection.

#### Position Confirmation:

Remote end of travel confirmation can be provided by adding a top mounted limit switch box. A variety of switch options and housings are available  
See our LSB range for details.

#### Position control:

The standard on/ off function can be converted to modulating function, using either a 3-15psi or 4-20mA control signal, by adding a pneumatic or electro-pneumatic positioner.  
See our YT range for details.



### Quick guide to the CH-air A Type actuator standard features :

*Robust rack and pinion construction*

*High accuracy machining of components*

*ATEX Ex II 2 GD approved for use in hazardous areas*

*CE Approved*

*Guaranteed for 1,000,000 cycles*

*Balanced air & spring strokes in spring return version*

*Safe to dismantle for routine maintenance*

*Compliant with all actuator standards*

*Accessories are easy to mount*

*Hard anodised aluminium body*

*ENP coated option  
(Extra cost)*

*Teflon® coated option  
(Extra cost)*

*Stainless steel version  
(Extra cost)*



# Model 2411/2412



Doc: CH-2411/02

Nov 2007

**Air operated heavy duty stainless steel ball valve with kit - Dimensions (to nearest mm)**

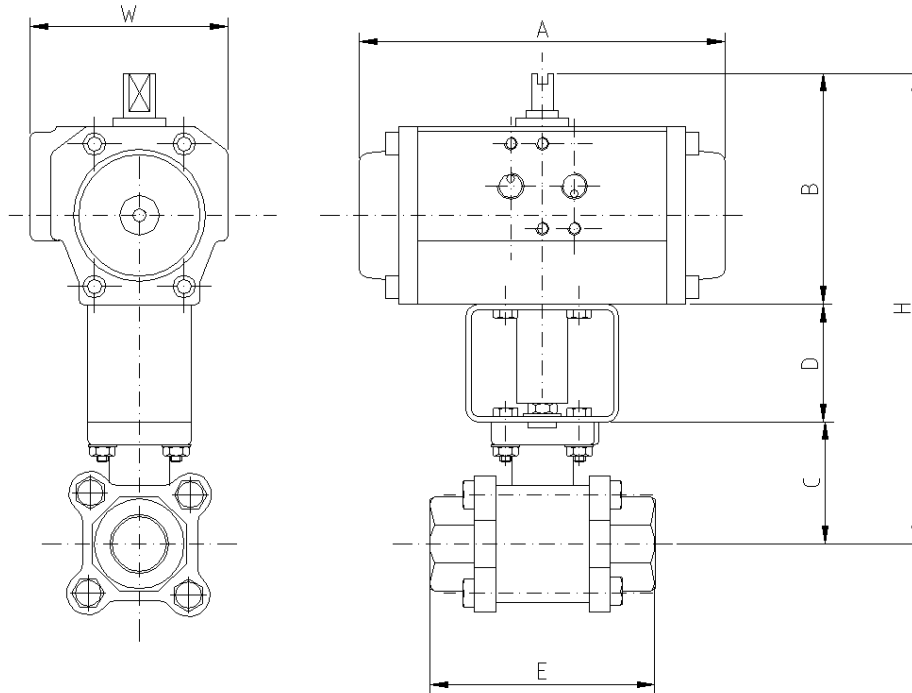

Double Acting										
	Model	A	B	C	D	E	H	W	Kilos	Bore 'd'
1/2"	CH042	160	77	43	50	75	170	61	1.9	12.6
3/4"	CH042	160	77	43	50	73	170	61	2.0	15.0
1"	CH042	160	77	47	50	85	174	61	2.6	20.0
1 1/4"	CH063	156	103	59	50	105	212	86	4.0	25.0
1 1/2"	CH063	156	103	63	50	111	216	86	6.1	32.0
2"	CH075	210	120	79	50	127	249	94	8.4	38.0
Spring Return										
1/2"	CH063SR	156	103	43	50	75	196	86	2.9	12.6
3/4"	CH063SR	156	103	43	50	75	196	86	2.9	15.0
1"	CH063SR	156	103	47	50	85	200	86	3.6	20.0
1 1/4"	CH075SR	210	120	59	50	105	229	94	5.7	25.0
1 1/2"	CH075SR	210	120	63	50	111	233	94	7.8	32.0
2"	CH085SR	228	130	79	50	127	259	104	10.2	38.0



# Valve Data Sheet



Doc SBV-M88/03

Nov 2007

## Direct mount 3 pce heavy duty stainless steel ball valve



### Specifications:

Construction	3 Pce Reduced bore direct mount ball valve
Size Range (Full)	1/4" to 2" BSP
Pressure Rating	3000 psi max
Valve Body Material	ASTM A351CF8M
Trim Material	ASTM A351CF8M
Seat Material	Carbon filled PTFE
Seal Material (Options)	PTFE
Inspection & Test	API 598 BS6755 Pt I
Standards	ANSI B16.34, ANSI I6.25, ANSI B1.20, API 6D ISO5211 DIN 259, DIN 2999, DIN3337. MSS SP25
Certification	EN 10204 3.1b on request
Temperature Range	-20 to +200C

### Approvals:

Approved ?



PED/97/23/EC



ATEX 94/9/EC  
II 2 GD



API 607 4th Ed'n /  
BS6755 Pt 2



TA-Luft



### DIMENSIONS (mm)

H, B1 DIMENSIONS ± mm

SIZE	øA		B1		B2		øC		øD		ød1		ød2		E		F		øG		H		J		L		L1		L2		øM1		øM2		øX1		øX2		P		ISO5211		Wt(Kg)												
	F	R	F	R	F	R	F	R	F	R	F	R	F	R	F	R	F	R	F	R	F	R	F	R	F	R	F	R	F	R	F	R	F	R	F	R	F	R	F	R	F	R													
1/4"	14.0		8.1		42.6		11.5		14.0		9.24		11.8		139		9.0		14.0		78.3		1.75		72.5				10		36		42		6		6		3		F03 & F04		0.88												
3/8"	17.6		8.1		42.6		12.6		17.5		12.53		13.6		139		9.0		17.5		78.3		1.75		72.5				10		36		42		6		6		3		F03 & F04		0.88												
1/2"	21.7		8.1		42.6		15.0		12.6		15.76		18.0		139		9.0		21.7		78.3		1.6		72.5		72.5		10		36		42		6		6		3		F03 & F04	F03 & F04	0.82 0.88												
3/4"	27.3		9.6		46.9		15.0		27.2		20.96		24.0		139		9.0		27.2		82.6		1.6		85.4		72.5		75		13		36		42		6		6		3		F03 & F04	F03 & F04	1.29 0.82										
1"	34.1		11.4		59.3		25.0		34		26.64		30.5		165		11.0		34.0		98.5		1.6		105.3		85.4		89.8		13		42		50		42		6		7		6		5		3		F04 & F05	F03 & F04	2.01 1.29				
1 1/4"	42.8		11.4		62.6		32.0		42.8		35.08		39.0		165		165		11.0		42.7		101.8		1.6		111		109.4		13		42		42		50		50		6		7		5		5		F04 & F05	F04 & F05	2.76 2.01				
1 1/2"	48.7		11.4		79.0		38.0		48.6		40.49		45.0		215		165		14.0		48.6		127		101.8		1.6		114.4		13		50		42		50		7.5		6		9		7		10		5		F05 & F07	F04 & F05	4.21 2.76		
2"	61.0		14.1		87.7		50.0		60.5		52.51		56.5		215		215		14.0		60.5		135.6		1.6		145		130		16		50		50		70		7.5		7.5		9		9		10		10		F05 & F07	F05 & F07	5.93 4.21		
2 1/2"	77		16.8		108.7		65.0		76.3		65.7		70.7		262		215		17		19		14.0		76.3		1.6		185		145		16		50		102		70		10		7.5		12		9		16		10		F07 & F10	F05 & F07	12 6.88
3"	90		17.8		117.7		80.0		90		90				262		262		17		19		19		90.0		1.6		205		185		16		70		102		102		10		10		12		12		16		16		F07 & F10	F07 & F10	16.2 12
4"	115.2		16.8		133.7		100.0		116		116				312		262		17		19		116.0		1.6		240		205		20		70		102		102		10		10		12		12		16		16		F07 & F10	F07 & F10	25.8 16.2		

