



Model 2601/2602



Doc: CH-2601/02

Nov 2007

Air operated hygienic stainless steel ball valve

2 Way 3 piece stainless steel ball valve, cavity filled seats, ends imperial OD butt weld or clamp type, polished wetted parts, designed for automation with integrally cast ISO5211 actuator mounting platform, fitted with direct mounted CH-air 'A' type pneumatic actuator. Supplied assembled and dry bench function tested. A minimum of 80 psi (5.5 bar) air supply pressure to the actuator is required.

2601 With double acting actuator

2602 With spring return actuator

Size range 1/2" to 4" (Butt & socket weld end options)

Applications:

Water, foodstuffs and most solvents and alkalis, subject to compatibility with wetted parts in contact with media. Actuators sized on a maximum differential pressure of 10 bar wet service, if the intended duty is above this differential, or dry (air or gas) call to check actuator sizing as a larger output actuator may be required.

Maximum working temperature of valve & actuator assembly is +70C. If the intended duty is at a higher temperature than this, select Model 2511/ 2512 which has a mounting kit fitted between the valve and actuator which uses air cooling to dissipate the heat away from the actuator (maximum +130C).

Valve Specifications:

Body	CF3M Cast 316SSL
Ball	CF3M Cast 316SSL
Seats	Cavity filled PTFE
Pressure rating	UTI 2" 64 bar, rest 50 bar
Valve temp limits	-20 to +200°C
Actuator temp limits	-20 to + 70°C

Accessories:

Solenoid control:

This provides electrical control of the valve. The air is constantly supplied to the solenoid which in turn controls the air to and from the actuator. The solenoid direct mounts to the actuator using the actuator's Namur connection.

Position Confirmation:

Remote end of travel confirmation can be provided by adding a top mounted limit switch box. A variety of switch options and housings are available
See our LSB range for details.

Position control:

The standard on/ off function can be converted to modulating function, using either a 3-15psi or 4-20mA control signal, by adding a pneumatic or electro-pneumatic positioner.
See our YT range for details.



Quick guide to the CH-air A Type actuator standard features :

Robust rack and pinion construction

High accuracy machining of components

ATEX Ex II 2 GD approved for use in hazardous areas

CE Approved

Guaranteed for 1,000,000 cycles

Balanced air & spring strokes in spring return version

Safe to dismantle for routine maintenance

Compliant with all actuator standards

Accessories are easy to mount

Hard anodised aluminium body

*ENP coated option
(Extra cost)*

*Teflon® coated option
(Extra cost)*

*Stainless steel version
(Extra cost)*



Model 2601/2602



Doc: CH-2601/02

Nov 2007

Air operated 2 way stainless hygienic steel ball valve - Dimensions (to nearest mm)

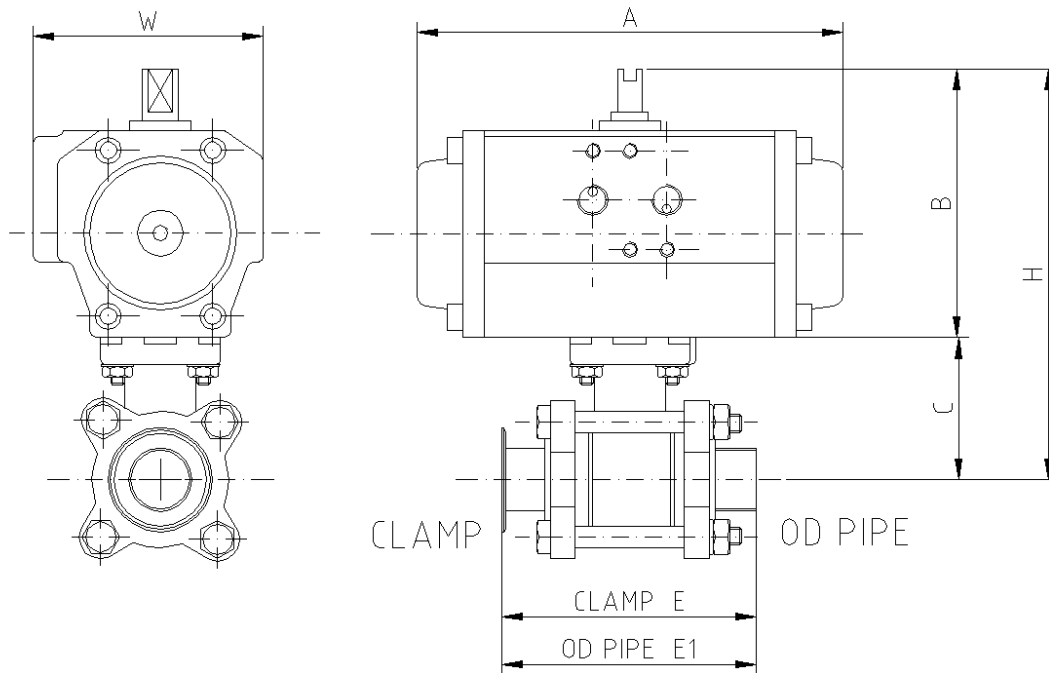

Double Acting									
	Model	A	B	C	E	E1	H	W	Kilos
1/2"	CH042	160	77	42	89	135	119	61	1.7
3/4"	CH050	138	87	48	101	141	135	75	1.9
1"	CH050	138	87	57	115	162	144	75	2.4
1 1/2"	CH075	210	120	61	140	182	164	94	3.6
2"	CH075	210	120	78	159	192	198	94	6.1
Spring Return									
1/2"	CH063SR	156	103	42	89	135	145	86	2.8
3/4"	CH063SR	156	103	48	101	141	151	86	2.8
1"	CH063SR	156	103	57	115	162	160	86	3.3
1 1/2"	CH075SR	210	120	61	140	182	181	94	5.3
2"	CH085SR	228	130	78	159	192	208	104	7.9

Sizes 2 1/2" to 4" available on request



Valve Data Sheet



Doc SBV-M77SN/01

Nov 2007

Hygienic direct mount 3 piece stainless steel ball valve

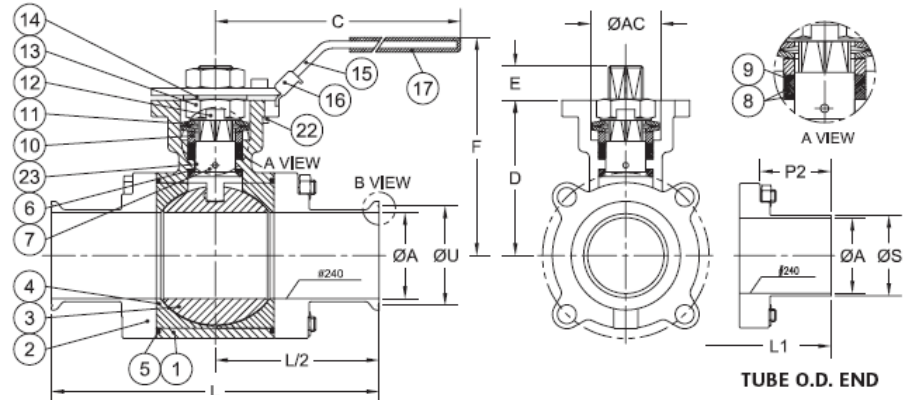

Specifications:

Construction	3 Pce direct mount ball valve
Size Range (Full)	1/2" to 4" BSP
Pressure Rating	1000 psi max
Valve Body/ Ends Material	ASTM A351 CF3M
Ball Material	SS 316L
Seat Material	Cavity filled PTFE
Seal Material (Options)	PTFE
Inspection & Test	API 598 BS6755 Pt 1
Standards	ANSI B16.34, ANSI 16.25, ANSI B1.20, API 6D ISO5211 DIN 259, DIN 2999, DIN3337. MSS SP25
Certification	EN 10204 3.1b on request
Temperature Range	-20 to +200C

Approvals:

Approved ?



PED/97/23/EC



ATEX 94/9/EC
II 2 GD



API 607 4th Ed'n /
BS6755 Pt 2



TA-Luft



Dimensions:

Size	A	B	C	D	DD1	DD2	E	F	L	L1	P2	S	U	V	Z1	Z2	AC	AD	LBS	ISO5211
1/2"	0.37	0.354	5.47	1.66	1.417	1.654	0.25	3.03	3.51	5.50	1.92	0.50	-	0.99	0.24	0.24	0.92	0.430	1.5	F03/F04
3/4"	0.62	0.354	5.47	1.89	1.417	1.654	0.27	3.27	4.00	5.75	1.96	0.75	-	0.99	0.24	0.24	0.92	0.430	1.8	F03/F04
1"	0.87	0.433	6.50	2.23	1.654	1.969	0.44	3.74	4.51	6.25	2.00	1.00	1.71	1.99	0.24	0.28	1.14	0.563	2.7	F04/F05
1-1/2"	1.37	0.551	8.47	3.05	1.969	2.756	0.56	5.00	5.52	7.50	2.23	1.50	1.71	1.99	0.28	0.34	1.54	0.744	7.0	F05/F07
2"	1.87	0.551	8.47	3.35	1.969	2.756	0.56	5.28	6.26	8.50	2.46	2.00	2.20	2.52	0.28	0.34	1.54	0.744	9.8	F05/F07
2-1/2"	2.37	0.669	11.81	4.28	2.756	4.016	0.67	6.54	6.85	9.75	2.55	2.50	2.78	3.05	0.34	0.47	2.07	0.885	19.6	F07/F10
3"	2.87	0.669	14.57	4.63	2.756	4.016	0.71	6.93	7.61	10.50	2.69	3.00	3.28	3.58	0.34	0.47	2.07	0.885	25.9	F07/F10
4"	3.83	0.669	14.57	5.22	2.756	4.016	0.67	7.48	8.90	12.50	3.14	4.00	4.34	4.68	0.34	0.47	2.07	0.885	47.4	F07/F10