



Model 3741/3742



Doc: CH-3741/01

July 2007

COMER Air operated 2 way uPVC ball valve

Full bore uPVC valve, fitted with CH-air 'A' type pneumatic actuator. Standard version has EPDM seals, but Viton (FPM) seals are available as an option. Supplied assembled and dry bench function tested. Minimum of 80 psi (5.5 bar) air supply pressure to the actuator is required.

3741 With double acting actuator

3742 With spring return actuator

Full size range from 1/2" to 4" (D20 to D110)

WRAS approved product for use on potable water.

Applications:

PVC is odourless and tasteless and is used in many applications such as potable water and many food processing. PVC has good chemical resistance and resists most solutions of acids, alkalis and salts, and solvents that can be diluted with water acids. It is not resistant to aromatic and chlorinated carbons.

Actuators sized on a maximum differential pressure of 10 bar wet service, if the intended duty is above this differential, or dry (air or gas) call to check actuator sizing as a larger output actuator may be required.

Valve Specifications:

Body	PVC
Ball	PVC
Seats	PTFE
Pressure rating	UTI 2" 16 bar, rest 10 bar
Valve temp limits	0 to +60°C
Actuator temp limits	-20 to + 70°C

Accessories:

Solenoid control:

This provides electrical control of the valve. The air is constantly supplied to the solenoid which in turn controls the air to and from the actuator. The solenoid direct mounts to the actuator using the actuator's Namur connection.

Position Confirmation:

Remote end of travel confirmation can be provided by adding a top mounted limit switch box. A variety of switch options and housings are available
See our LSB range for details.

Position control:

The standard on/ off function can be converted to modulating function, using either a 3-15psi or 4-20mA control signal, by adding a pneumatic or electro-pneumatic positioner.
See our YT range for details.



Quick guide to the CH-air A Type actuator standard features :

Robust rack and pinion construction

High accuracy machining of components

ATEX Ex II 2 GD approved for use in hazardous areas

CE Approved

Guaranteed for 1,000,000 cycles

Balanced air & spring strokes in spring return version

Safe to dismantle for routine maintenance

Compliant with all actuator standards

Accessories are easy to mount

Hard anodised aluminium body

*ENP coated option
(Extra cost)*

*Teflon® coated option
(Extra cost)*

*Stainless steel version
(Extra cost)*



Model 3741/3742



Doc: CH-3741/01

Nov 2006



Air operated PVC ball valve - Dimensions (to nearest mm)

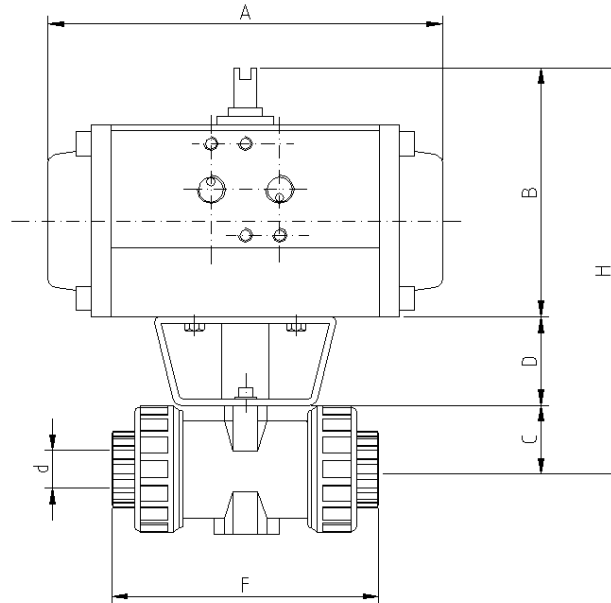

Double Acting										
Imperial	Model	A	B	C	D	F	H	Width	Kilos	Metric Pipe OD / Bore 'd'
1/2"	CH042	160	77	25	50	102	152	61	1.0	20 / 15
3/4"	CH042	160	77	30	50	120	158	61	1.1	25 / 20
1"	CH042	160	77	34	50	128	161	61	1.4	32 / 25
1 1/4"	CH042	160	77	40	50	147	167	61	1.5	40 / 32
1 1/2"	CH050	138	87	48	50	163	185	75	1.7	50 / 40
2"	CH063	156	103	58	50	197	211	86	2.5	63 / 50
2 1/2"	CH063	156	103	73	50	214	226	94	3.6	75 / 65
3"	CH075	210	120	83	50	241	253	94	6.0	90 / 80
4"	CH075	210	120	105	70	281	295	104	7.9	110 / 100
Spring Return										
1/2"	CH050SR	138	87	25	50	102	162	75	1.5	20 / 15
3/4"	CH050SR	138	87	30	50	120	167	75	1.6	25 / 20
1"	CH050SR	138	87	34	50	128	171	75	1.7	32 / 25
1 1/4"	CH050SR	138	87	40	50	147	177	86	1.9	40 / 32
1 1/2"	CH063SR	156	103	48	50	163	201	86	2.8	50 / 40
2"	CH075SR	210	120	58	50	197	228	94	4.6	63 / 50
2 1/2"	CH075SR	210	120	73	50	214	243	104	5.4	75 / 65
3"	CH085SR	228	130	83	50	241	263	104	7.9	90 / 80
4"	CH100SR	281	145	105	70	281	320	134	12.9	110 / 100