

Model U-0 Unidirectional IP65 Weatherproof Electric Actuator



General:

The U-0 is a base entry electric actuator offering unidirectional travel (rotates in the same direction), manual override and 2 volt free position confirmation switches as standard.

With the same wiring connections for AC & DC power supplies and with external DIN plug connections, eliminating the need to remove the actuator's cover to connect, the U-0 is quick and easy to install.

Specifications:

Housing	Polyamide (Nylon 6)
Duty rating	35%
Drive connection	ISO5211 & DIN 3337
Electrical connection	External via DIN plugs
Torque output	15Nm break, 15Nm running
Temp range	-10°C to +50°C
Working time	Varies with supply voltage
Supply voltages	12, 24V DC; 24, 110 & 240AC
Current 240V	200 mA
Current 110V	350mA
Weight	1.5 kg

Installation:

The U-0 actuator is remarkably simple to install as all electrical connections are made without removing the actuator's cover - the supplied DIN plugs are wired in accordance with the opposite wiring diagram, re-connected to the actuator and the U-0 is ready for use. The U-0 can be mounted in any orientation but vertical orientation is preferred. Read supplied installation & operating instructions before use.

Features:

- > Separate models 12V DC to 240V AC
- > Manual override
- > Local & remote position indication
- > External DIN plug connections - No need to remove cover to connect
- > Corrosion resistant housing
- > IP65 weatherproof
- > Economically priced

TYPE U-0

Dimensions:

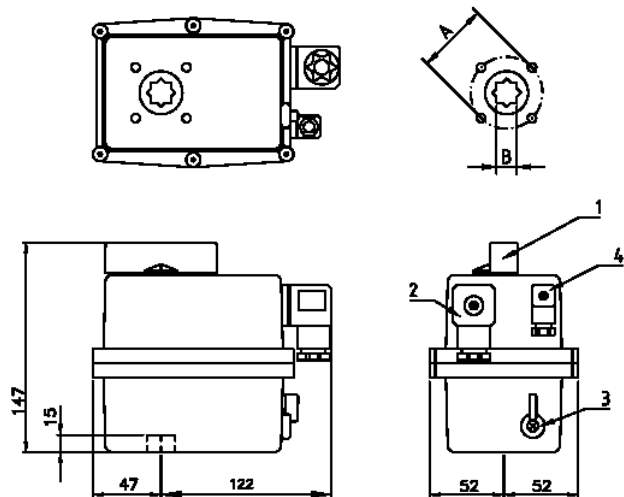

On/off, stays put on power failure: Type J2-H20

- | | | |
|---|--|---------------|
| 1 | Manual override & local position indicator | A: F03 or F05 |
| 2 | Power supply DIN plug | B: 11 or 14mm |
| 3 | Manual override selector lever | A: ISO5211 |
| 4 | Volt free limit switch DIN plug | B: DIN3337 |

Wiring Diagram (AC or DC):

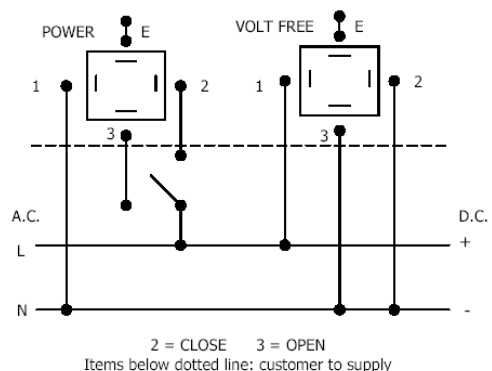

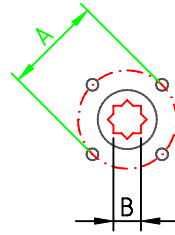
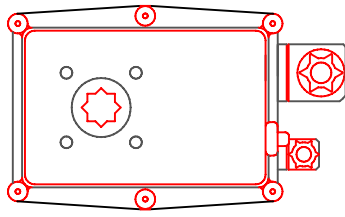

OUTPUT DRIVE DIMENSIONS			
	F03	F04	F05
A	36	42	50
B	9	11 or 14	11 or 14
According to ISO5211 / DIN3337			

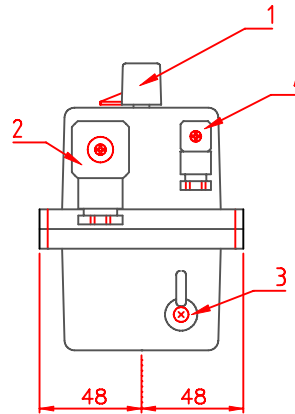
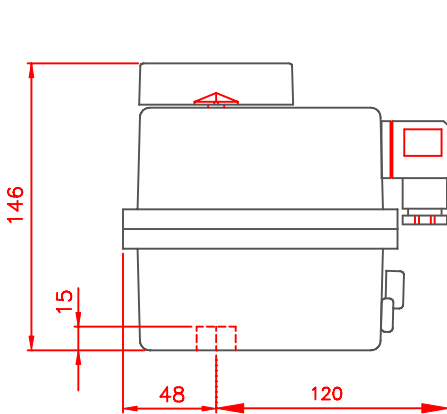

- 1- Local position indicator & Manual Override operator
- 2- Mains power connector
- 3- Manual Override selector
- 4- Volt free contact connector

On receipt of a continuous power signal, the motor runs and via a planetary gearbox, rotates the output shaft. The motor is stopped by internal cams fitted to the output shaft striking micro switches. When a subsequent continuous signal is received, the motor will turn in the same direction. 2 volt free contacts, via cams and micro switches are fitted as standard.

- + Corrosion resistant housing.
- + All Din plug connections eliminating the need to remove actuator cover to connect.

Optional Extra: Anti-condensation heater / thermostat.

Note: Not available failsafe or modulating.



VOLTAGE	VDC	12	24	110			
	VAC				24	110	220/240
CURRENT	A	1.8	1	0.3	1.2	0.35	0.2
WORKING TIME	S/90°	9			7.5	5	
STARTING TORQUE	Nm				15		
WORKING TORQUE	Nm				15		
DUTY RATING	%				35		
PROTECTION	-				IP 65		
WORKING ANGLE	°				90°		
WEIGHT	KG				1.5		
TEMPERATURE	°C				-20 +70		
CONNECTORS	-	DIN 43650-B/ISO 4400 & C-192					

MODEL UO ELECTRIC ACTUATOR

J+J
ACTUATORS

Drawn By
MRG

Chk
DC

File Name
9406

Scale
NTS

Dwg No. 9406

Revision
2

Sheet
1/1

Date
06/09/01

POWER CONNECTION

AC/DC SUPPLY

VOLT FREE CONTACT CONNECTION

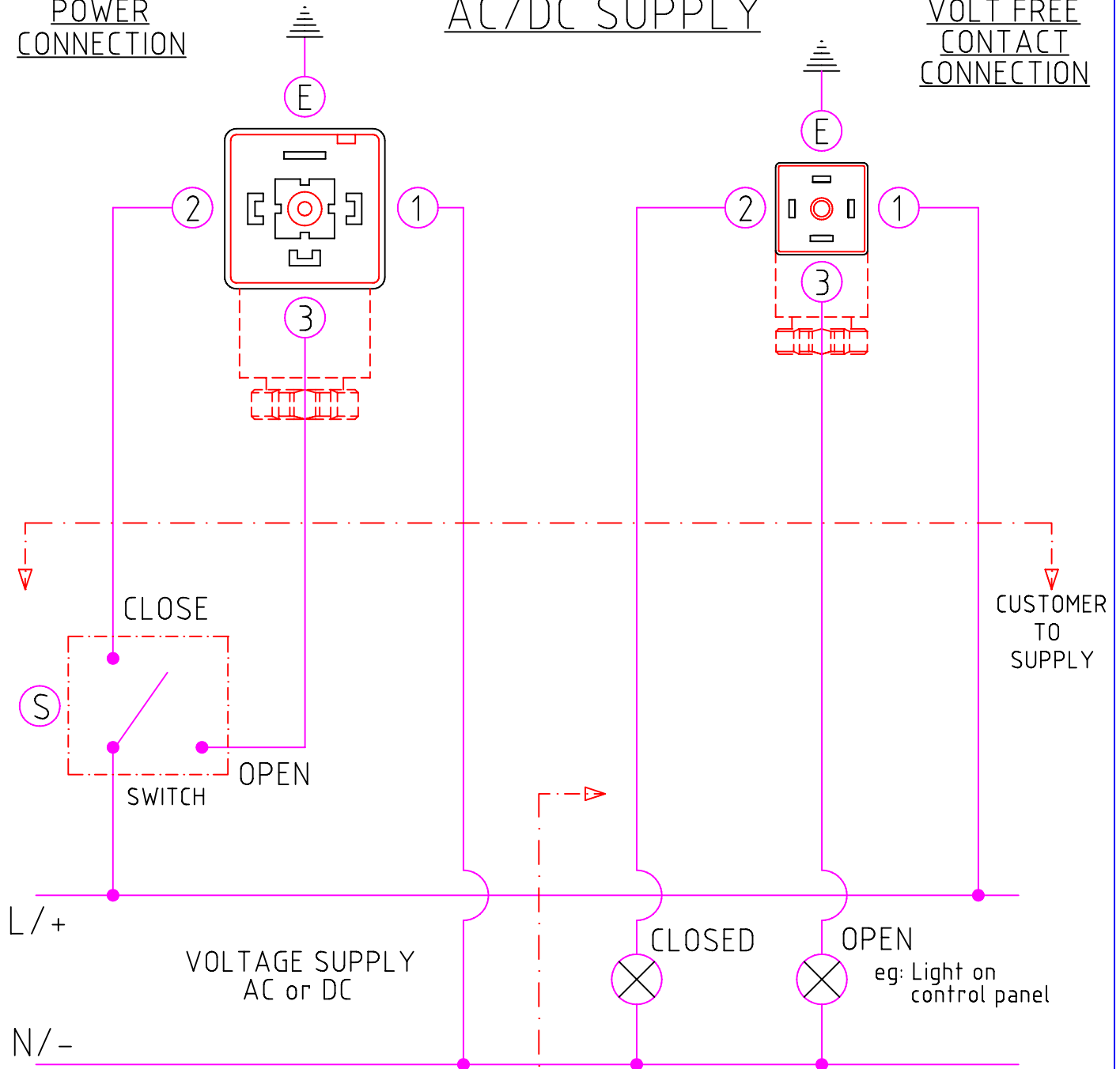

(S) = SWITCH (to supply continuous signal until end of travel is reached).
 eg: THERMOSTAT
 RELAY
 FLOAT/LEVEL SWITCH
 MANUAL SWITCH
 ETC.

VOLT FREE CONTACTS
 Factory set at 0 & 90°
 Switches rated 220V 5A

Above wiring showing same supply as motor is only a suggestion.

NB: READ INSTALLATION, OPERATION & MAINTENANCE INSTRUCTIONS BEFORE CONNECTING.

AC/DC WIRING DIAGRAM U-0 UNIDIRECTIONAL ACTUATOR.

J+J
 ACTUATORS

Drawn By MRG	Chk DC	File Name WU	Scale NTS
Dwg No. WU	Revision 1	Sheet 1/1	Date 14/06/00

INSTALLATION, OPERATION & MAINTENANCE INSTRUCTIONS

Read these instructions fully before attempting to use the actuator as damage caused by non-compliance will invalidate any warranty. If in doubt, ask your supplier BEFORE you connect it.

1 ELECTRICAL CONNECTION

- 1.1 All J+J actuators have wiring diagrams attached to the side of the actuator on initial supply. Do not remove these diagrams as doing so may invalidate any warranty.
- 1.2 All J+J actuators have Din plug electrical connectors eliminating the need to remove the cover to connect electrically. Removing the cover is not necessary and doing so may invalidate any warranty. Ensure the rubber seal is correctly installed when refitting the plug after wiring to maintain IP65 rating. The Din plugs need to be fitted to maintain its IP65 rating, but take care not to over tighten the securing screws.
- 1.3 **WARNING – DANGER OF SHORT CIRCUITING** – never connect the open and closed pins (except with failsafe models) as this will short circuit the actuator causing irreparable damage and invalidating the warranty. If in doubt, ASK before you connect the power supply.
- 1.4 **WARNING – Overload protection.** We strongly recommend that the actuator is given its own independent fused supply to prevent current from other devices being drawn through the actuator which will cause irreparable damage and invalidate any warranty.

2 MANUAL OVERRIDE

- 2.1 All J+J actuators have a manual override facility, operated by a selector lever, which disengages the motor drive when moved from AUTO to MAN (Manual). The gearbox contains planetary gears and it may be necessary to 'wobble' the selector lever whilst gently moving the manual override handle to ensure the gears disengage and re-engage. When resetting into AUTO – a positive 'click' will be felt when the gears have correctly disengaged/ re-engaged – again, 'wobble' the selector lever if required. Fitted in all reversible models (prefix 'R'), is a safety cut out switch activated by the manual override selector lever, which cuts the power to the motor when in the 'MAN' position.
- 2.2 NEVER remove the selector lever retaining screw as this will allow the operating mechanism to become free and will cause irreparable damage to the actuator's gearbox. Removing this screw will invalidate any warranty.
- 2.3 When in AUTO mode, the manual override operating handle rotates on models U0, R0 and R1 – NEVER restrict this movement or irreparable damage will be caused which will invalidate any warranty. Forcing this override handle to move whilst in 'AUTO', when the actuator is not being operated electrically, will irreparably damage the drive mechanism and invalidate any warranty.
- 2.4 When in MAN mode, avoid rotating the actuator beyond the open and closed logos printed on the top of the actuator. There are no mechanical stops fitted to the actuator (to allow rotations of 120 and 180 degrees) and it is therefore possible to over rotate the actuator. Over rotation will position the internal cams beyond their micro switches, which will result in an abnormal first operation of the actuator when reset into AUTO mode (the actuator will rotate up to 270 degrees until the cam resets in the correct position).
- 2.5 In models where the power is not cut by the manual override selector lever (U0), NEVER leave the actuator in 'MAN' mode if the power supply is controlled by an external source (timer/ control panel etc) as upon receiving a signal to operate, the motor will run continuously as the drive is disengaged, and the motor will burn out, invalidating any warranty.
- 2.6 Open and closed logos are as follows:

OPEN



CLOSED



3 APPLICATION / SIZING

Correctly sized and used within the parameters of the specification of the actuator, over 10 year manufacturing experience shows the J+J actuators will provide trouble free service. NEVER operate the J+J actuators on equipment that can exceed the stated torque as it will cause irreparable damage and invalidate any warranty. Always allow a healthy safety margin when sizing.

STANDARD MODELS – POWER OPEN, POWER CLOSE INSTALLATION INSTRUCTIONS

J+J actuators operate using live electricity and we recommend that only qualified electrical engineers/ electricians be employed to connect the actuators electrically. These user friendly actuators can be fully connected without removing the actuator's cover using the external Din plugs and wiring diagrams affixed to the side of the actuator.

In AC power supplied models, a switch has to be provided by the user to switch the live between open and closed, and in some DC power supplied models, the polarity has to be reversed by components supplied by the user.

IOM's FOR ALL STANDARD ON/OFF ACTUATORS

J+J ACTUATORS	Drawn By MRG	Chk DC	File Name MSW.JJIOM	Scale NTS
	Dwg No. STD.IOM	Revision 2	Sheet 1/2	Date 04/09/01

- I.1 Check that the voltage being applied matches the voltage shown on the actuator's identification label as damage caused by applying an incorrect voltage will invalidate any warranty.
- I.2 Connect the power supply as per the wiring diagram affixed to the side of the actuator. If in doubt, ASK BEFORE connecting.
- I.3 All J+J actuators are supplied with volt free position confirmation switches (limit switches) which require a separate power supply to operate (rated 240V 5A). The suggested wiring as per the wiring diagram affixed to the side of the actuator shows the same voltage for the actuator being used as the power source for these switches – this is a suggestion only and any standard control voltage can be used (eg: 12 or 24DC).
- I.4 We strongly disapprove of the use of mechanical stops as any physical restriction to the full rotation of the actuator will cause irreparable damage to the gearbox and/or burn out the motor, either invalidating any warranty.
- I.5 Whilst the J+J actuators can be fitted in any orientation subject to ambient/ environmental conditions, we recommend installing the actuator vertically wherever possible. Be aware of applications where elevated temperatures could be present and allow for the possibility of heat rising – in these cases use an extended mounting kit to help dissipate the heat. In applications where ambient conditions (humidity/ temperature) can fluctuate dramatically, we recommend the fitting of internal anti-condensation heaters..
- I.6 If in doubt at any point, ASK before connecting. Common sense and good engineering practice should always prevail.

OPERATING INSTRUCTIONS – STANDARD POWER OPEN, POWER CLOSE MODELS

Irreparable damage can easily be caused to J+J actuators through incorrect operation. Ensure the operator is aware of the rotation of the actuator – model U0 is unidirectional, all others are reversing - and exercise extreme caution if, against our recommendations, mechanical stops are to be employed.

These actuators work with the use of cams which operate limit switches, which control the power to the actuator's motor. These cams are factory set at 0 and 90 degrees and whilst they are adjustable, should not normally require any user adjustment.

- O.1 Supply a continuous (not pulse) live signal (either open, or close live) to operate the actuator. The actuator will rotate until the cams operate the micro switch and cut the power to the motor. The actuator will stay in this position until a further continuous live signal is received to send it to its next position. The rest positions will be shown by the open and closed logos, as indicated by a local visual position indicator. NEVER move the set position of this indicator or a false position will be indicated.
- O.2 In the case of mains power failure, the actuator will stay in the position it saw at the moment of power interruption. Should the actuator need to be operated under these circumstances, use the manual override facility, but remember to reset the selector lever in the AUTO position when the movement is completed as outlined earlier.
- O.3 The corrosion resistant housings of the J+J electric actuators are by their nature, not as rust as aluminium housed actuators and should be treated with care. NEVER support or lift an actuated assembly by the actuator or it may break causing irreparable damage and invalidating any warranty.

MAINTENANCE INSTRUCTIONS

The J+J electric actuators are designed to be maintenance free, the gearbox is factory lubricated for life and there are no other parts requiring maintenance. Simple external cleaning using soapy water will remove deposits and ensure the open and closed logos remain visible. NEVER pressure wash the actuators as they are not designed to withstand this form of cleaning and irreparable damage caused by pressure washing will invalidate any warranty.

OPTIONS

- A FAILSAFE electric actuators. A separate IOM sheet is supplied with failsafe J+J actuators
- B Modulating electric actuators. A separate IOM sheet is supplied with modulating J+J actuators.

SPECIAL BESPOKE ACTUATORS

We can supply special configuration actuators in certain circumstances which will be supplied with instructions specific to that build. However, the general IOM's contained in this document will still apply.

MANUFACTURER'S PRODUCT SUPPORT

J+J actuators are fully supported in the UK and Ireland and manufacturer's representatives can attend site to assist with 'problems', however a call out charge is made and expenses are recovered if the fault is proven to be 'user generated' due to non adherence to these IOM's. An order number MUST be issued to cover these charges BEFORE they will attend. Should the fault be due to manufacturing or material defects, no charge will be made.

Thank you for purchasing the J+J electric actuator. We trust that you will find them very user friendly and that if installed and operated in accordance with these instructions, you will find they give reliable and trouble free performance. E&OE Rev2 9.01

IOM's FOR ALL STANDARD ON/OFF ACTUATORS

J+J ACTUATORS	Drawn By MRG	Chk DC	File Name MSW.JJIOM	Scale NTS
	Dwg No. STD.IOM.	Revision 2	Sheet 2/2	Date 04/09/01