

ELECTRICALLY OPERATED ON/OFF 2 WAY PVC BALL VALVE



Features:

- > Full bore for maximum flow rate
- > Compact assembly
- > Corrosion resistant materials
- > Valve rated at 16 bar uti 2" at 20°C
- > J2 Smart Redbox electric actuator
- > Local & remote visual position indication
- > Quick and easy to install
- > Economically priced

TYPE 3203 1/2" to 4"

General:

uPVC is ideal for conveying potable water as it is odourless and tasteless, and for conveying food products. It has excellent chemical resistance.

The J2 Smart Redbox electric actuator offers multi-voltage capability, electronic torque limiter, anti-condensation heater, local and remote position confirmation and manual override.

Same wiring connection for AC & DC power supplies, with external DIN plug connections, eliminating the need to remove the actuator's cover to connect.

Specifications:

Valve body	uPVC
Valve ball	uPVC
Ball seats	PTFE
Stem seals	EPDM (Viton option)
Valve pressure range	16 bar uti 2", 10 bar rest*
Valve temp. limits	-20C to +80C **
Supply voltage to actuator	24DC/ 24, 110 or 240V AC

Applications:

Water, air & many corrosive medias, subject to compatibility with wetted parts in contact with media.

Pressure ratings shown are at 20°C

* Actuators sized using max differential of 6 bar wet service – if this is to be exceeded, call to check actuator sizing.

** Actuator temperature limit = -20C to +70C. For applications above this temperature, call us for advice.

Installation:

Can be mounted in any orientation although valve horizontal with actuator vertical is preferred. Valve ends are imperial or metric solvent weld, or BSP (Specify on order)

Actuator details:

The J2 'Smart RedBox' range of CE marked reversible electric actuators offer unrivalled standard features and is an exceptionally user-friendly product.

- * L Series accepts 24V AC or DC –automatic voltage sensing.
- * H Series accepts 110 to 240V AC or DC– auto voltage sensing.
- * Electronic torque limiter to protect against valve blockages.
- * Internal heater protects against condensation.
- * Protected against short circuit by incorrect connection.
- * Same 3 wire connecting capability for AC or DC supply.
- * Manual override with safety power cut out when operated.
- * Local and remote position confirmation.
- * Corrosion resistant housing.
- * IP65 weatherproof housing.
- * All external connecting—no need to remove covet to connect.
- * Corrosion resistant housing.
- * Stainless cover screws.
- * Trackable serial numbering system.
- * ISO 9001 manufactured.
- * 100% function tested on assembly.

The J2 has been designed to be quick and easy to install -simply connect to the external DIN plugs. Once installed, the J2 should give excellent service due to its many protective features.

Wiring Diagram (AC or DC):

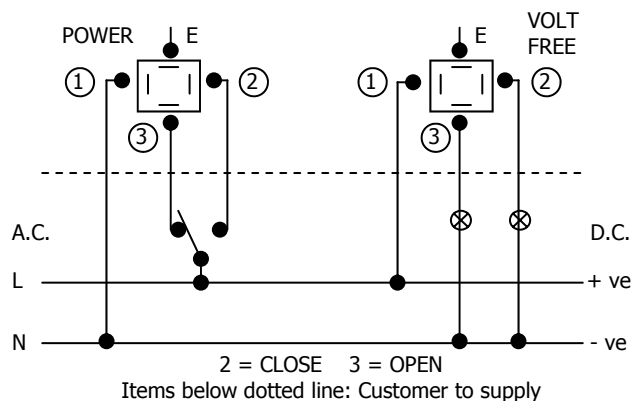

J2-H20 'Smart Redbox' IP65 Weatherproof Electric Actuator

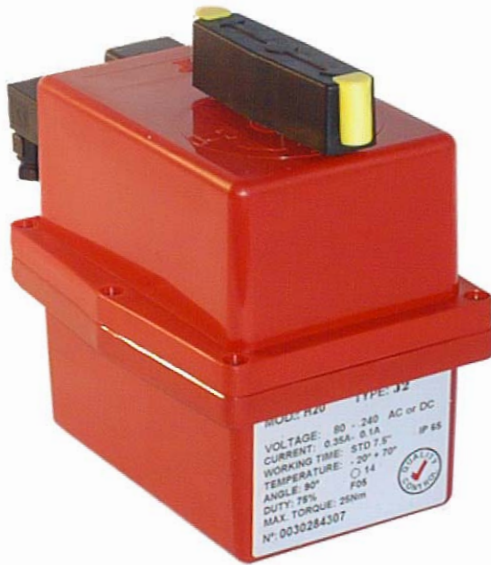

General:

The J2 Smart Redbox electric actuator offers multi-voltage capability, electronic torque limiter, anti-condensation heater, local and remote position confirmation and a manual override with safety cut-out switch when activated.

Same wiring connections for AC & DC power supplies and with external DIN plug connections, eliminating the need to remove the actuator's cover to connect, the J2 is quick and easy to install.

Specifications:

Housing	Polyamide (Nylon 6)
Duty Rating	75%
Drive connection	ISO5211 & DIN 3337
Electrical connection	External via DIN plugs
Torque output	25Nm break, 20Nm running
Temp range	-20°C to +70°C
Working time	8 secs ± 10%, no load
Supply voltages	80~240V AC or DC
Current 240V aC	85 mA 20.9 W
Current 110V AC	180 mA 19.8 W
Weight	1.5 kg

Installation:

The J2 Smart Redbox is remarkably simple to install as all electrical connections are made without removing the actuator's cover - the supplied DIN plugs are wired in accordance with the opposite wiring diagram, re-connected to the actuator and the J2 is ready for use. The J2 can be mounted in any orientation but vertical orientation is preferred. Read supplied installation & operating instructions before use.

Features:

- > **Auto-voltage sensing**
- Accepts 80-240V AC & DC
- > **Electronic torque limiter**
- Protects against valve jams
- > **Anti-condensation heater**
- Protects against condensation
- > **Manual override**
- > **External DIN plug connections**
- No need to remove cover to connect

TYPE J2-H20

Dimensions:

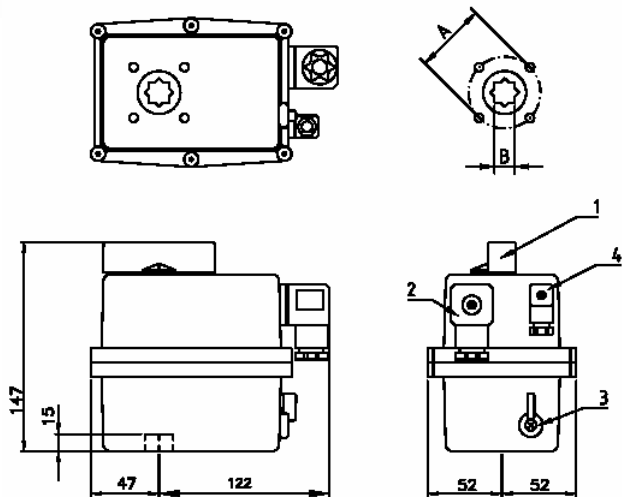

On/off, stays put on power failure: Type J2-H20

- | | | |
|---|--|---------------|
| 1 | Manual override & local position indicator | A: F03 or F05 |
| 2 | Power supply DIN plug | B: 11 or 14mm |
| 3 | Manual override selector lever | A: ISO5211 |
| 4 | Volt free limit switch DIN plug | B: DIN3337 |

Wiring Diagram (AC or DC):

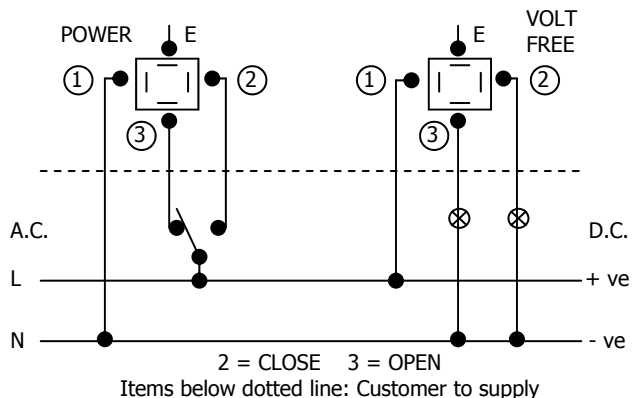

J2-L20 'Smart Redbox' IP65 Weatherproof Electric Actuator

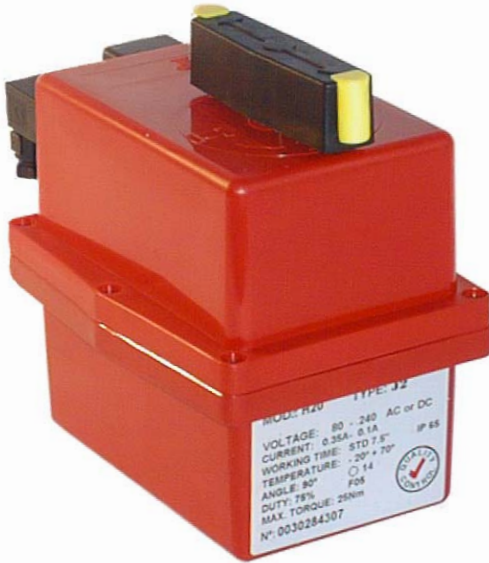

Features:

- > **Auto-voltage sensing**
- Accepts 24~48V AC & DC
- > **Electronic torque limiter**
- Protects against valve jams
- > **Anti-condensation heater**
- Protects against condensation
- > **Manual override**
- > **External DIN plug connections**
- No need to remove cover to connect

TYPE J2-L20

General:

The J2 Smart Redbox electric actuator offers multi-voltage capability, electronic torque limiter, anti-condensation heater, local and remote position confirmation and a manual override with safety cut-out switch when activated.

Same wiring connections for AC & DC power supplies and with external DIN plug connections, eliminating the need to remove the actuator's cover to connect, the J2 is quick and easy to install.

Specifications:

Housing	Polyamide (Nylon 6)
Duty Rating	75%
Drive connection	ISO5211 & DIN 3337
Electrical connection	External via DIN plugs
Torque output	25Nm break, 20Nm running
Temp range	-20°C to +70°C
Working time	8 secs ± 10%, no load
Supply voltages	24~48V AC or DC
Current 24V DC	900 mA 21.6 W
Current 24V AC	1900 mA 45.8 W
Weight	1.5 kg

Installation:

The J2 Smart Redbox is remarkably simple to install as all electrical connections are made without removing the actuator's cover - the supplied DIN plugs are wired in accordance with the opposite wiring diagram, re-connected to the actuator and the J2 is ready for use. The J2 can be mounted in any orientation but vertical orientation is preferred. Read supplied installation & operating instructions before use.

Dimensions:

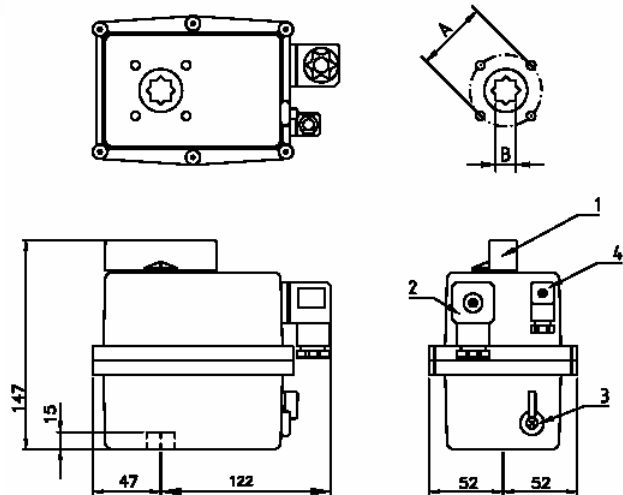

On/off, stays put on power failure: Type J2-L20

- | | | |
|---|--|---------------|
| 1 | Manual override & local position indicator | A: F03 or F05 |
| 2 | Power supply DIN plug | B: 11 or 14mm |
| 3 | Manual override selector lever | A: ISO5211 |
| 4 | Volt free limit switch DIN plug | B: DIN3337 |

Wiring Diagram (AC or DC):

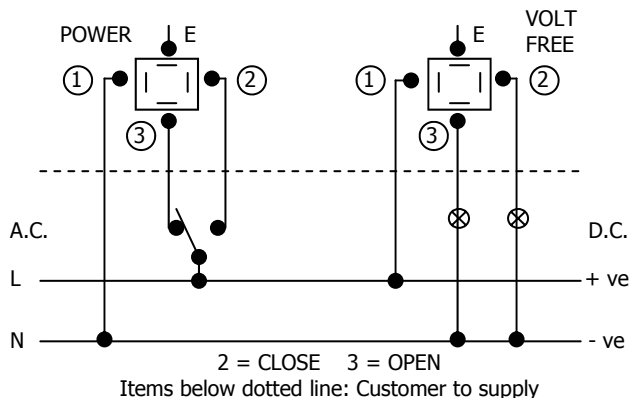

FULL BORE uPVC BALL VALVE



- > **Full bore gives maximum flow**
- > **Actuators mount via kit**
- > **PN16 Rated UTI 2"**
- > **Imperial or metric sockets**
- > **Blow-out proof ball**
- > **Low torque**
- > **WRAS listed (Potable Water)**

TYPE BV-A73

GENERAL	VALVE TYPE	FULL BORE 1/4 TURN BALL VALVE	
	VALVE MODEL	BV-A73	
	OPERATOR	HAND OPERATED WITH LEVER, OR BY ACTUATOR	
	DESIGN STANDARDS	MANUFACTURERS OWN, BASED ON EN-1452-2 & EN-1452-3	
	FACE TO FACE DIMS	MANUFACTURERS OWN	
	TESTING STANDARDS	MANUFACTURERS OWN	
	CERTIFICATION	CERTIFICATE OF CONFORMITY ONLY -MASS PRODUCED ITEM	
	ACTUATOR MOUNTING	MOUNTS WITH MOUNTING KIT	
	SIZE RANGE	3/8" TO 4"	
	PRESSURE RATING	PN16 UTI 2", ABOVE 2" = PN10	
TEMPERATURE LIMITS	WORKING PRESSURE BASED AT 20C		
MATERIALS	BODY	PVC-U	
	BALL	PVC-U	
	STEM(BLOW-OUT PROOF)	PVC-U	
	SEATS	PTFE	
	SEALS	EPDM OR VITON	
	END CONNECTIONS	SOLVENT SOCKET OR BSPP	
FEATURES	ANTI-STATIC DEVICE	NO	
	FIRE SAFE	NO	
	PRIMARY STEM SEAL	RUBBER O RING	
	SECONDARY STEM SEAL	RUBBER O RING	
	STEM SEAL ADJUSTMENT	NO	
	IN-LINE MAINTAINABLE	NO	
OTHER	WRAS Listed for use on potable water.		

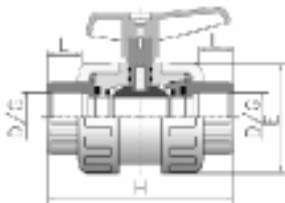

D	CODE	REF.	DN	PN	L	H	E
16	18434	05 73 016	15	16	16	84	52
20	18435	05 73 020	15	16	16	84	52
25	18436	05 73 025	20	16	19	108	62
32	18437	05 73 032	25	16	22	124	70
40	18438	05 73 040	32	16	26	142	84
50	18439	05 73 050	40	16	31	167	104
63	18440	05 73 063	50	16	38	198	120
75	18441	05 73 075	65	10	44	232	148
90	18442	05 73 090	80	10	51	269	179
110	22799	05 73 111	100	10	63	359	228

J2 SMART REDBOX – INSTALLATION, OPERATION & MAINTENANCE INSTRUCTIONS

Read these instructions **BEFORE** attempting to use the actuator as damage caused by non-compliance will invalidate any warranty. If in any doubt, ask your supplier **BEFORE** using it.

STANDARD FEATURES:

AVS (Auto Voltage Sensing)

The J2 actuator has multi-voltage capability – it can accept a range of AC or DC power supply voltages. The J2-L series can accept from 16V to 48V AC or DC, the J2-H series from 80 to 240V AC or DC.

PES (Protected Electrical Supply)

The J2 is protected against erroneous electrical connection – if the open live and closed live terminals are inadvertently connected, whilst the actuator will not operate, no internal damage should be caused. There are no fuses. Damage will only be caused by applying a voltage in excess of 48V AC or DC to the 'L' series actuators.

ETL (Electronic Torque Limiter)

An electronic torque limiter is fitted to all J2 actuators. The ETL constantly monitors the motor load and immediately cuts the motor power supply if the 'set point' is exceeded. An internal LED, in models 20 & 55, visible through the actuator's housing, provides constant status indication: constantly lit LED = actuator working normally, flashing LED = fault warning, the torque in the valve has exceeded the 'set point'. This advises operators that a problem has arisen with the valve (eg: blockage). A flashing LED indicates a fault with the valve, not the actuator. The ETL automatically 'backs off' when activated to relax the gears, allowing the manual override to be used to assist in clearing the blockage. Once the cause of the excess torque has been cleared, the J2 will automatically reset, the LED will change to being constantly lit, and the actuator will start operating again. See instructions overleaf.

ATC (Auto Temperature Control)

An inbuilt thermostat and heater maintains the internal temperature at around 30°C to prevent the possibility of condensation forming within the housing. This system does not require a separate power supply, it is fed from the main power supply. The power supply must remain on at all times for the heater to operate.

MO (Manual Override)

All J2 actuators have a manual override facility to allow manual operation in the event of power failure. Selection of manual ('MAN') operation operates an internal switch which cuts the motor power – the actuator will not operate electrically whilst in manual.

VFC (Volt Free Contacts)

All J2 actuators have an additional pair of volt free mechanical micro-switch contacts which are typically used for remote position confirmation. These switches are NOT to be used for actuator motor control.

Plus: IP65 weatherproof housing, but not suitable for submersion, flooding, hose down or pressure washing. 75% duty cycle. Corrosion resistant housing with stainless cover fixings. All external electrical connection via DIN plugs, eliminating the need to remove the cover to connect. ISO5211 and DIN3337 mounting. Local visual position indicator, CE marked, ISO9002 manufactured. Serial numbered and traceable.

QUICK AND EASY TO INSTALL

These user friendly actuators are designed to be fully connected **WITHOUT REMOVING THE ACTUATOR COVER** via externally supplied DIN plugs, simply wire the plugs and they are ready for use ! A wiring diagram label showing how to wire the plugs is affixed to the side of the actuator.

Standard wiring (3 wire) for either AC or DC power supply is identical with a common, and a live switch between open and close. However, for DC power supplies, the actuators will also operate on a 2 wire system with a user supplied voltage polarity switch, used to reverse the motor, if this wiring configuration is preferred.

PEACE OF MIND

The J2 actuators are fully guaranteed against manufacturing and/ or material defects, for 12 calendar months from the date of despatch from our works.

Thank you for purchasing the J2 Smart RedBox. We trust that you will find them very user friendly and that if installed and operated in accordance with the following instructions, they will give you reliable and trouble free performance.

E&OE 12-02 Rev 3

INSTALLATION, OPERATION & MAINTENANCE INSTRUCTIONS

STANDARD J2 ELECTRIC ACTUATORS (POWER OPEN, POWER CLOSE)

INSTALLATION INSTRUCTIONS

J2 actuators operate using live electricity and we strongly recommend that only qualified electricians/ electrical engineers be employed to make electrical connections. They are quick and easy to connect without removing the cover, do not remove the cover without our authorisation or the warranty may be invalidated:

- I.1 Check that the voltage being applied matches the voltage shown on the actuator's identification label and connect the power supply cables to the DIN plug(s) as per the wiring diagram affixed to the side of the actuator. Removing any label will invalidate the warranty. Wiring can be the same for AC or DC (3 wire), or 2 wire DC with a customer supplied voltage polarity switch, which is needed to reverse the motor. If in doubt, ASK BEFORE CONNECTING. Ensure that the rubber seal is refitted between the Din plug and base to maintain the IP65 seal. Do not over-tighten the plug securing screw.
- I.2 Do not connect a power supply voltage in excess of 48V to the low voltage (J2-L) series as irreparable damage will be caused and any warranty invalidated.
- I.3 If the volt free plug is not being used, leave the plug fitted to the actuator to maintain its IP65 weatherproof rating. Take care not to knock the DIN plugs as this may pull the DIN plug base away from the actuator which in turn will break the body seal and permit water to access the housing. Damage of this nature invalidates any warranty.
- I.4 All J2 actuators are supplied with volt free position confirmation switches (limit switches) that require a separate power supply to operate (rated 240V 5A) The suggested wiring as per the wiring diagram affixed to the side of the actuator shows the same voltage for the actuator being used as the power source for these switches – this is a suggestion only and any standard control voltage can be used (eg: 24VDC).
- I.5 Whilst the J2 actuators can be fitted in any orientation we recommend installing the actuator vertically wherever possible. Be aware of applications where elevated temperatures could be present and allow for the possibility of heat rising – in these cases use an extended mounting kit to help dissipate the heat, and mount the actuator horizontally.

OPERATING INSTRUCTIONS

These actuators work with the use of cams which operate limit switches which control the starting, stopping, and direction of rotation of an electric motor. These cams are factory set at 0 and 90 degrees and whilst they are adjustable, should not normally require any user adjustment.

- O.1 Supply a continuous (not pulse) live signal (either open live, or close live) to operate the actuator. The actuator will rotate until the cams operate the micro switch and cut the power to the motor. The actuator will stay in this position until a further continuous live signal is received to send it to its opposite position. The in-built heater uses this mains supply and therefore the power supply voltage should remain on at all times.
- O.2 The rest positions are as per the moulded open and closed logos, indicated by a local visual position indicator. NEVER move the set position of this indicator or a false position will be indicated.
- O.3 In the case of mains power failure, the actuator will stay in the position it saw at the moment of power interruption. Should the actuator need to be operated under these circumstances, use the manual override facility, but remember to reset the selector lever in the AUTO position when the movement is completed as selection of 'MAN' cuts the power to the motor.
- O.4 All J2 actuators have an electronic torque limiter which cuts the motor power if the applied torque exceeds the actuators rated output. Visual status indication is provided in models 20 & 55 by an internal LED which remains continuously lit when working normally, but flashes when the limiter is activated. A flashing LED indicates a problem with the valve, not the actuator. (Cut the power, clear the cause of the excess torque eg: valve jammed, turn power back on and the limiter will reset allowing normal operation)

MANUAL OVERRIDE

- 1.1 All J2 actuators have a manual override facility, operated by a selector lever which disengages the motor drive when moved from AUTO to MAN (Manual). The gearbox contains planetary gears and it may be necessary to 'wiggle' the selector lever whilst gently moving the manual override handle to ensure the gears disengage and re-engage. When resetting into AUTO – a positive 'click' will be felt when the gears have correctly re-engaged. A safety cut out switch activated by the manual override selector lever, which cuts the power to the motor when in the MAN position. When MAN is selected, the actuator will not operate electrically.
- 1.2 NEVER remove the selector lever retaining screw as this will allow the operating mechanism to become free and will cause irreparable damage to the actuator's gearbox. Removing this screw will invalidate any warranty.
- 1.3 When in AUTO mode, the manual override operating handle rotates on models 20 & 55 – restricting this rotation may activate the ETL. In these circumstances, switch off the power, leave a few seconds and turn back on – the ETL will automatically reset
- 1.4 When in MAN mode, avoid rotating the actuator beyond the open and closed logos moulded on the top of the actuator. There are no mechanical stops fitted to the actuator (to allow rotations of 120 and 180 degrees) and it is therefore possible to over rotate the actuator. Over rotation will position the internal cams beyond their micro switches which will result in abnormal first following operation of the actuator when reset into AUTO mode (the actuator may rotate up to 450 degrees until the cam resets in the correct position).

A yellow indicator identifies the open and closed logos:



MAINTENANCE

- M.1 These actuators are designed to be maintenance free, the gearbox is factory lubricated for life and there are no internal parts that require maintenance.