

Model J2 300

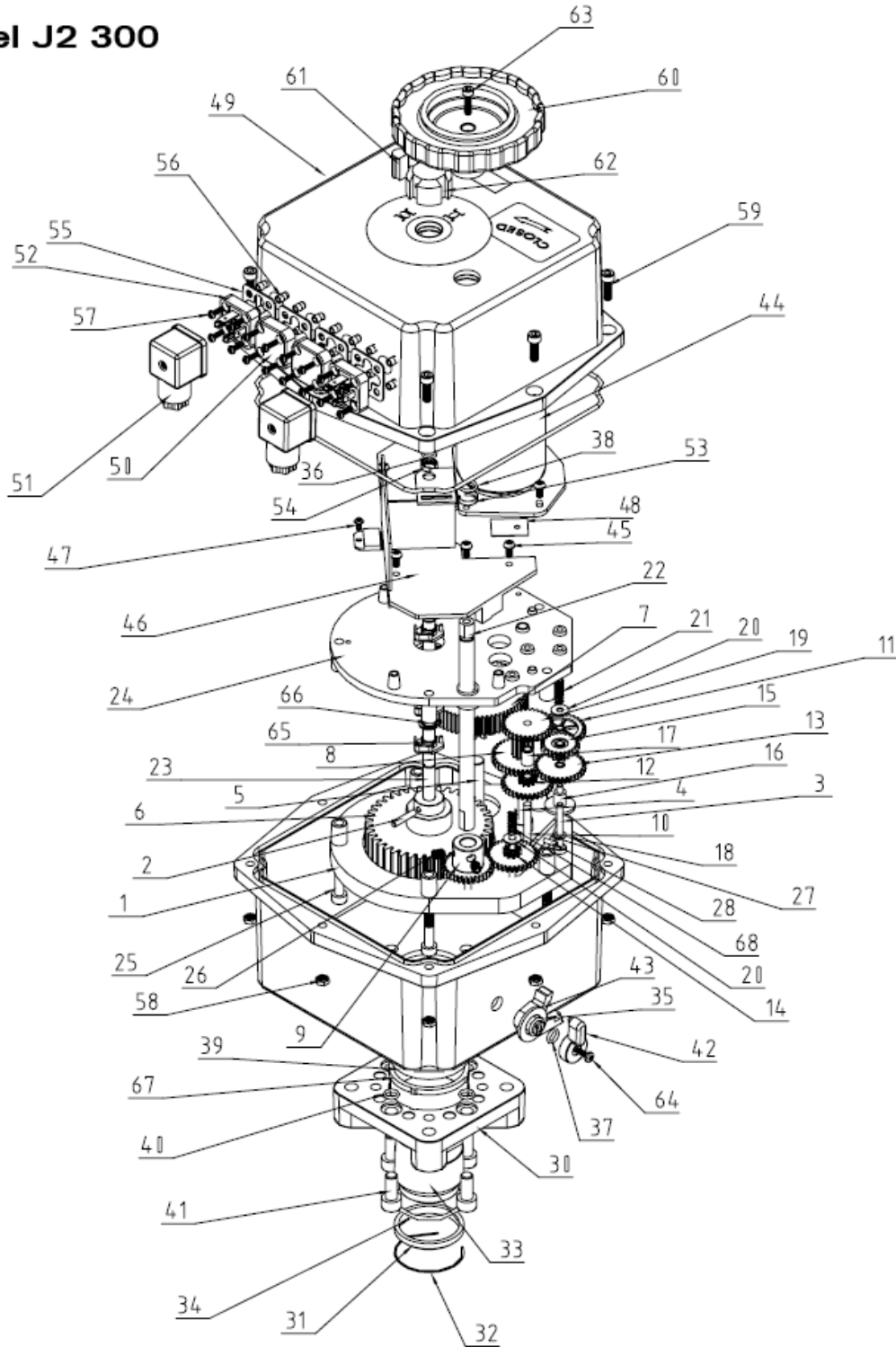

J2**Exploded View J2-300**

Doc: J2-300.EV/01

March 2007

ITEM	QTY	DESCRIPTION
1	1	INFERIOR BASE PLATE
2	2	PIN 1
3	3	PIN 2
4	1	PIN 3
5	1	PIN 4
6	1	OUTPUT GEAR
7	1	GEAR 1
8	1	GEAR 2
9	1	HAND WHEEL GEAR
10	1	PIN 5
11	1	GEAR 5
12	1	GEAR 3
13	1	GEAR 4
14	1	GEAR 8
15	1	GEAR 6
16	1	BUSHING 1
17	1	BUSHING 2
18	1	WASHER 1
19	1	GEAR 7
20	2	WASHER 2
21	2	SPRING 1
22	1	HAND WHEEL SHAFT
23	1	OUTPUT SHAFT
24	1	UPPER BASE PLATE
25	5	PLATE SCREW
26	2	THREADED STUD 1
27	1	ROCKER ARM
28	1	PIN 5
29	1	BODY
30	1	FLANGE
31	1	WASHER 3
32	1	OUTPUT CIRCLIP
33	1	OUTPUT DRIVE
34	1	O-RING 1
35	1	O-RING 2
36	1	O-RING 3
37	1	O-RING 4
38	1	O-RING 5
39	1	O-RING 6
40	4	O-RING 7
41	4	FLANGE SCREW
42	1	EXTERNAL DISENGAGEMENT
43	1	INTERNAL DISENGAGEMENT
44	1	ELECTRIC MOTOR
45	7	MOTOR SCREW
46	1	PRINT CIRCUIT BOARD
47	2	PCB SCREW
48	1	INSULATOR
49	1	COVER
50	2	ACCESSORIES COVER
51	2	BIG CONNECTOR
52	2	BASE BIG CONNECTOR
53	1	BUSHING 1
54	1	BUSHING 2
55	4	JOINT
56	16	INSERT
57	16	FASTENING SCREW BASE CON
58	8	NUT
59	8	SCREW COVER
60	1	HAND WHEEL
61	1	VISUAL POSITIONN INDICATOR
62	1	INDICATOR CAM
63	1	HAND WHEEL SCREW
64	1	DISENGAGEMENT SCREW
65	4	CAM
66	4	SEGEER CIRCLIP
67	1	FLANGE BUSHING
68	1	SPRING