

J2

Model I40 BSR Failsafe Electric Actuator



Doc: J2-I40BSR/02/KW
Aug 2010

J2 – I40 BSR IP65 Failsafe Electric Actuator

The maintenance free **J2** electric actuator is very user friendly. It offers more standard features than any rivals in its class, and was first to the market with both multi-voltage capability with automatic voltage sensing, and an electronic torque limiter with auto-gearbox relaxing which frees the manual override when a valve is jammed. The manual override facility, with a safety power cut-out switch when operated, allows safe hand operation .

Time saving external DIN plugs allow installations to be pre-wired and eliminates the need to remove the cover to connect the actuator, which helps to reduce installation costs.

With a soft start system eliminating high motor start loads and a thermostatic anti-condensation heater that does not require a separate connection, the **J2** offers low power consumption.

The IP65 weatherproof plastic housing with stainless steel cover screws offers high corrosion resistance.

Local visual position indication and remote volt free end of travel confirmation are provided as standard.

The **J2** is quick and easy to install:

- ISO:5211 multi-flange F07 or F10 mounting with a 22mm female double square (star) drive.
- Factory set open and closed positions at 0 and 90° (or as specified on your order).
- External electrical connections and external wiring diagram - no need to remove the cover to connect.



Always read the supplied installation & operating instructions before use.

J2 - I40 BSR ~ Failsafe version (factory option)

Battery 'Spring Return' (BSR) Note: This is not a mechanical spring return system

This version fails to a pre-set fail safe position if the mains power fails (normally closed, or normally open).

Under normal operation the electric actuator works as a power open, power closed actuator, and during this operation, internal industrial rechargeable batteries are trickle charged to maintain them at full capacity. In the event of a mains power failure, the BSR system immediately switches to battery power, disables the torque limiter to ensure maximum torque is available and sends the actuator to the fail safe position.

On resumption of mains power, providing the valve actuator control signal remained unchanged, the actuator will re-set to the original position immediately prior to the power failure.

Main Features:

J2 Failsafe electric actuator

Multi-voltage capable with auto-voltage sensing:

J2-L140 12-48V AC/DC

J2-H140 80-240V AC/DC

Torque output:

170Nm Break

140Nm Reset

Electronic torque limiter ~ protects against valve jams. Disabled when battery works.

Anti-condensation heater

Manual override

All connections via external DIN plugs ~ no need to remove the cover to connect

Volt free end of travel confirmation switches

IP65 weatherproof housing

CE marked

Traceable sequential serial numbering system

Failsafe with Battery Back-up ~ actuator fails to safe position on mains power failure

Failsafe function can be changed from normally closed to normally open without removing the cover.

Specifications: J2-I40 BSR Electric actuator (Failsafe)

Models	J2 -HI40-BSR 80-240V AC (Iph) or DC (Normally closed) J2 -HI40-BSR-NO 80-240V AC (Iph) or DC (Normally open) J2 -LI40-BSR 12-48V AC (Iph) or DC (Normally closed) J2 -LI40-BSR-NO 12-48V AC (Iph) or DC (Normally open)
Housing	IP65 Anti-corrosive Polyamide
Duty Rating	75%
Mounting	ISO5211 (F07, I0) & DIN3337 (22mm Star)
Electrical Connection	External via DIN plugs
Torque Output	170Nm Break, 140Nm Run & re-seat
Temp Range	-20°C to +70°C
Working Time	31 Secs ± 10%, no load
Current 220VAC/ 110VAC	85 mA 20.9W / 180 mA 19.8W
Current 24VAC/ 24VDC	1900 mA 45.8W / 900 mA 21.6W
Weight	8 kg

Dimensions:

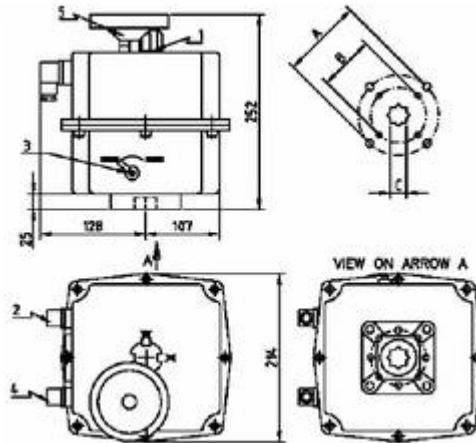

On/off, fails safe on power failure:

- 1 Local position indicator
- 2 Power supply DIN plug
- 3 Manual override selector lever
- 4 Volt free limit switch DIN plug
- 5 Manual override hand wheel
- 6 NC to NO changeover plug (not shown)
(Do NOT connect cables to this plug)

Wiring:

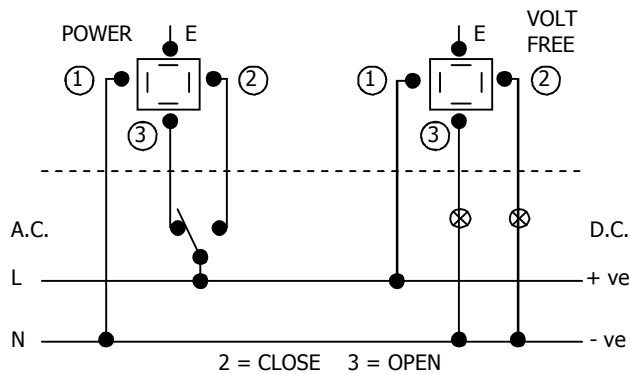

Wiring Diagram (AC or DC): 3 wire

- Notes:
- DIN plugs supplied with actuator
 - Power change-over switch not supplied