



# Model **J3C** – H55



Doc: J3C-LH55/01

Aug 2011

## Feature rich **J+J** multi-voltage electric actuator with LED status light and plug & play accessories.

New in 2008, the **J3** range of electric actuators took its highly successful predecessor, the J2 range, to the next level.

With its all new, rugged weatherproof and anti-corrosive Polyamide housing, the **J3** offered more user-friendly features than the J2, and introduces a highly visible LED status light.

This LED indicator showed whether the actuator is operating correctly, or has tripped out either by its electronic torque limiter, or has been left in 'manual' mode.

Site operators were no longer left with the 'valve or actuator?' question when an actuator doesn't respond to a signal.

In 2011 the **J3C** was introduced which has an all new dome position indicator and improved ingress protection to IP67.

The **J3C** is quick and easy to install, with ISO:5211 multi-flange mounting and a double square drive, allowing fast mounting to ISO:5211 valves.

There is no need to remove the cover to connect the **J3C** electrically, saving installation time.



Using the external DIN plugs and external wiring diagrams supplied with the actuator, installations could be pre-wired.

Protection against valve jams is provided by an electronic torque limiter, which auto-relaxes the gearbox when activated, allowing the manual override to be selected to assist in clearing the jam.

The effect of condensation is eliminated by an internal thermostatic anti-condensation heater that does not require a separate independent power supply.

Standard function for the **J3**-H55 electric actuator is power open, power close, stays put on power failure.

New to the **J3** were plug and play accessories –the function can be changed to either failsafe or modulating by fitting the new plug and play conversion kits.

The **J3C** continues to be a very smart red box!

### Quick guide to the **J3C**'s standard features :

*Multi-voltage with auto-voltage sensing.  
85 ~ 240V AC or DC .*

*LED Status light to indicate operational status of actuator*

*Electronic over-torque protection against valve jams*

*Thermostatic anti-condensation heater*

*Manual override for emergency hand operation*

*2 Volt free end of travel confirmation switches*

*IP67 weatherproof anti-corrosive and UV protected Polyamide housing*

*Dome visual position indicator*

*ISO5211 multi-flange mounting with double square drive*

*All external electrical connections via supplied DIN plugs*

*CE marked*

*ISO 9000 manufacturer*

*Made in the EU*

*Failsafe and digital positioner plug & play kits available.*

## **J3C** Status light functions:

Constantly lit LED

If the electric valve actuator is operating correctly with no faults, the LED shows a constantly lit light.



The LED flashes with 2 blinks

If the actuator has been left in 'manual' mode, the actuator's motor runs but doesn't drive the output shaft. After a pre-set time, the actuator knows that as the torque limiter has not activated and that the motor is running, it must be in manual.



The LED flashes on/ off

When the electric actuator senses an impending valve jam, the electronic torque limiter is activated and on activation, repeatedly flashes the LED on and off.





The new **J3C - 55**  
Quarter turn electric valve actuator

*Visual indication of the actuator's operating status is constantly shown by a highly visible LED light, and the new highly visible dome indicator, introduced in 2011*

## Specifications: **J3C – H55**

Voltage range - automatically sensed by actuator	85-240VAC (1ph) or DC
Operating time (0-90° no load)	14 seconds
Maximum break torque	60 Nm / 531 lb.ins
Maximum operating torque (run/ reseat)	55 Nm / 486 lb.ins
Duty rating	75%
IP Rating (IEC 60529)	IP67
Working angle Standard (on request)	90° (180° or 270° options)
Mounting ISO:5211 x DIN 3337	F05 & F07 x 17
Motor switches	2 x SPDT micro switches
End of travel confirmation (volt free)	2 x SPDT micro switches
Heater	4 W
Ambient temperature range	-20° to +70°C -4 to +158°F
Electrical connecting plugs	DIN 43650/ ISO4400 & C 192
Consumption:	
240V/1ph At maximum torque	0.12A
110V/ 1ph At maximum torque	0.23A
Weight	2.4 kg

## Materials of construction:

Housing	Anti-corrosive Polyamide
Fasteners	Stainless steel
Gears	Polyamide (speed reducing) & steel
Shaft	Stainless steel
Output drive	Zammac
Position indicator	Clear Polyamide

## Method of operation:

On receipt of a continuous power signal within the voltage range shown above, the motor runs and, via a flat gear system, rotates the output shaft. The motor is stopped by internal cams striking micro switches. On receipt of a reversing continuous signal, the motor turns in the opposite direction reversing the output drive.

Note:

The power signal needs to remain on at all times to activate the thermostatic anti-condensation heater.

The volt free end of travel confirmation switches must NOT be used to cut the power.

**Dimensions: J3C - H55**



Mounting	F05	F07
ISO: 5211	50mm	70mm
Drive	17mm	
Optional	14mm	

*The standard on-off version can have plug and play failsafe or modulating kits retro-fitted to convert the function.*

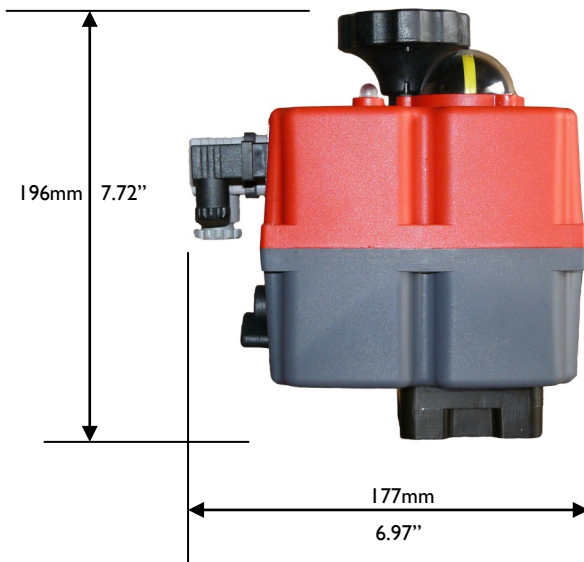

*The modulating kit contains a self calibrating digital positioner.*

**Change of function retro-fit kits:**

**Failsafe option**

This kit converts the actuator to a failsafe unit using a BSR (Battery 'Spring Return') system that provides an alternative (battery) power supply to set the electric actuator in the failsafe position should the main power supply fail.

It can be configured normally open, or normally closed.

**Modulating Option**

Using the new self calibrating and self adjusting digital positioning system, this kit converts the electric actuator into a modulating electric actuator using either a 4-20mA or 0-10VDC control signal.

An output signal is provided as standard.

**Failsafe modulating option**

Install both kits

