



Installation, Operation & Maintenance Instructions (IOM's) Model **J3** DPS.2005



Doc: IOM.DPS.2005/J3/02

Jan 2009

FUNCTION

The DPS.2005 is a self calibrating and auto-adjusting Digital Positioning System supplied as a retro-fit option to the **J3** range of reversible electric actuators to produce modulating functionality. The self calibrating feature senses the motor stop closed position and sets the span from this position, and then auto-calibrates the steps between open and closed for either 4-20mA or 0-10VDC control signals.

Should the actuator be rotated by hand beyond these positions whilst being operated in MAN (manual operation mode) and then returned to AUTO (automatic operation) whilst still outside the normal working quadrant as indicated by the open and closed logos moulded into the top of the actuator's cover, the DPS.2005 will auto adjust itself back into the normal working quadrant.

Hunting has been virtually eliminated in the DPS.2005 and as soon as the actuator arrives at the required position relative to the input signal, it stops.

The DPS.2005 provides a feedback signal (in the same format as the input signal) as standard.

INSTALLATION INSTRUCTIONS

These instructions are issued if an approved J+J agent installs the DPS plug & play conversion kit, and supplement the standard on-off IOM's

J3 actuators operate using live electricity and we strongly recommend that only qualified electricians/ electrical engineers be employed to make electrical connections as a matter of Health & Safety. They are quick and easy to connect without removing the cover, do not remove the cover without our authorisation or the **warranty may be invalidated**:

Check that the voltage being applied matches the voltage shown on the actuator's identification label and connect the power supply, control signal and volt free end of travel confirmation switch cables to the DIN plug(s) as per the wiring diagram affixed to the side of the actuator (copy on page 2 of these instructions). Ensure that polarity of the control signal cable is as per the wiring diagram. **Removing any label will invalidate the warranty**. Wiring is the same for AC or DC (2 wire). If in doubt, ASK BEFORE CONNECTING.

Ensure that the rubber seal is refitted between the Din plug and base to maintain the IP65 seal, failure to fit the seals will **invalidate the warranty**. Do not over-tighten the plug securing screw.

Do not connect a power supply voltage in excess of 24V to the low voltage (**J3-Lxx**) series as irreparable damage will be caused and any **warranty invalidated**.

If the volt free plug is not being used, blank off the cable entry to the DIN plug and leave the plug fitted to the actuator to maintain its IP65 weatherproof rating. Take care not to knock the DIN plugs as this may pull the DIN plug base away from the actuator which in turn will break the body seal and permit water to access the housing. Damage of this nature **invalidates any warranty**.

All **J3** actuators are supplied with volt free position confirmation switches (limit switches) that require a separate power supply to operate (rated 240V 5A) The suggested wiring as per the wiring diagram affixed to the side of the actuator shows the same voltage for the actuator being used as the power source for these switches – this is a suggestion only and any standard control voltage can be used (eg: 24VDC). The volt free end of travel confirmation switches are set slightly ahead of the motor stop positions - do not use the signal from these switches to cut the power to the motor.

Whilst the **J3** actuators can be fitted in any orientation we recommend installing the actuator vertically wherever possible. Be aware of applications where elevated temperatures could be present and allow for the possibility of heat rising – in these cases use an extended mounting kit to help dissipate the heat, and mount the assembly horizontally.

OPERATING INSTRUCTIONS

Supply a continuous (not pulse) live signal to power the actuator. The in-built heater uses this mains supply and therefore the power supply voltage should remain on at all times.

On receipt of a control input signal the actuator will move to the position relative to the input signal eg: using a 4-20mA signal, 4mA input signal closes the actuator, a 12mA signal sets the actuator at 45° and a 20mA signal opens the actuator. Each subsequent change of input signal will cause a corresponding change to the actuator position. This functionality can be reversed (reverse acting) if required. An output signal in the same form as the input signal is supplied as standard.

The rest positions are as per the moulded open and closed logos (see overleaf), indicated by a local visual position indicator. NEVER move the set position of this indicator or a false position will be indicated.

When the actuator is functioning correctly, the LED status light will be continuously lit.

In the case of control signal failure, the actuator will move to the closed position (or open if configured reverse acting). In the case of mains power failure, the actuator will stay in the position it saw at the moment of power interruption. Should the actuator need to be operated under these circumstances, use the manual override facility, but remember to reset the selector lever in the AUTO position when the manual movement is completed as selection of 'MAN' disengages the output drive. In manual mode the LED status light will blink twice.

All **J3** actuators have an electronic torque limiter (ETL) which cuts the motor power if the applied torque exceeds the actuators rated output eg: valve jammed. The LED status light will flash on-off. Sending a signal in the opposite direction to the jam will move the actuator away from the jam to use the flowing media to flush away the blockage, the LED will be continuously lit. Trying to operate in the direction of the original jam may now be successful, or a few attempts may be necessary. If the jam persists, isolate the actuator and valve and strip out to clear the blockage or check the valve.

Continued on page 2 . . .

Page 2

MANUAL OVERRIDE

All **J2** actuators have a selectable manual override facility, operated by a selector lever which disengages the motor drive when moved from AUTO (automatic operation) to MAN (manual operation). When MAN is selected, the actuator will not operate electrically, and after a short time-out the LED status light will blink twice.

NEVER remove the selector lever retaining screw as this will allow the operating mechanism to become free and will cause irreparable damage to the actuator's gearbox. Removing this screw will **invalidate any warranty**.

When in AUTO mode, the manual override operating handle rotates on models 20 to 85 – restricting this rotation may activate the ETL and cause the LED status light to flash on-off. In these circumstances, send a reversing signal – the ETL will automatically reset and the LED will be continuously lit.

The open and closed logos: moulded into the top cover look like this:



OPEN



CLOSED

WIRING DIAGRAM (AC or DC)

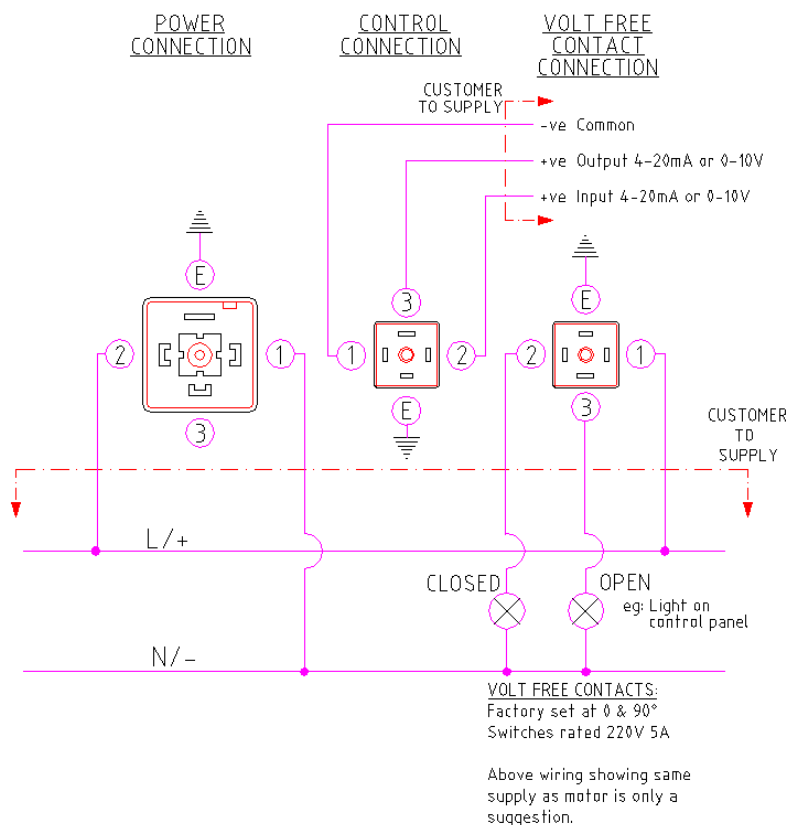

MAINTENANCE

J2 actuators are designed to be maintenance free, the gearbox is factory lubricated for life and there are no internal parts that require maintenance.

DO NOT PRESSURE WASH. Pressure washing invalidates the warranty.