

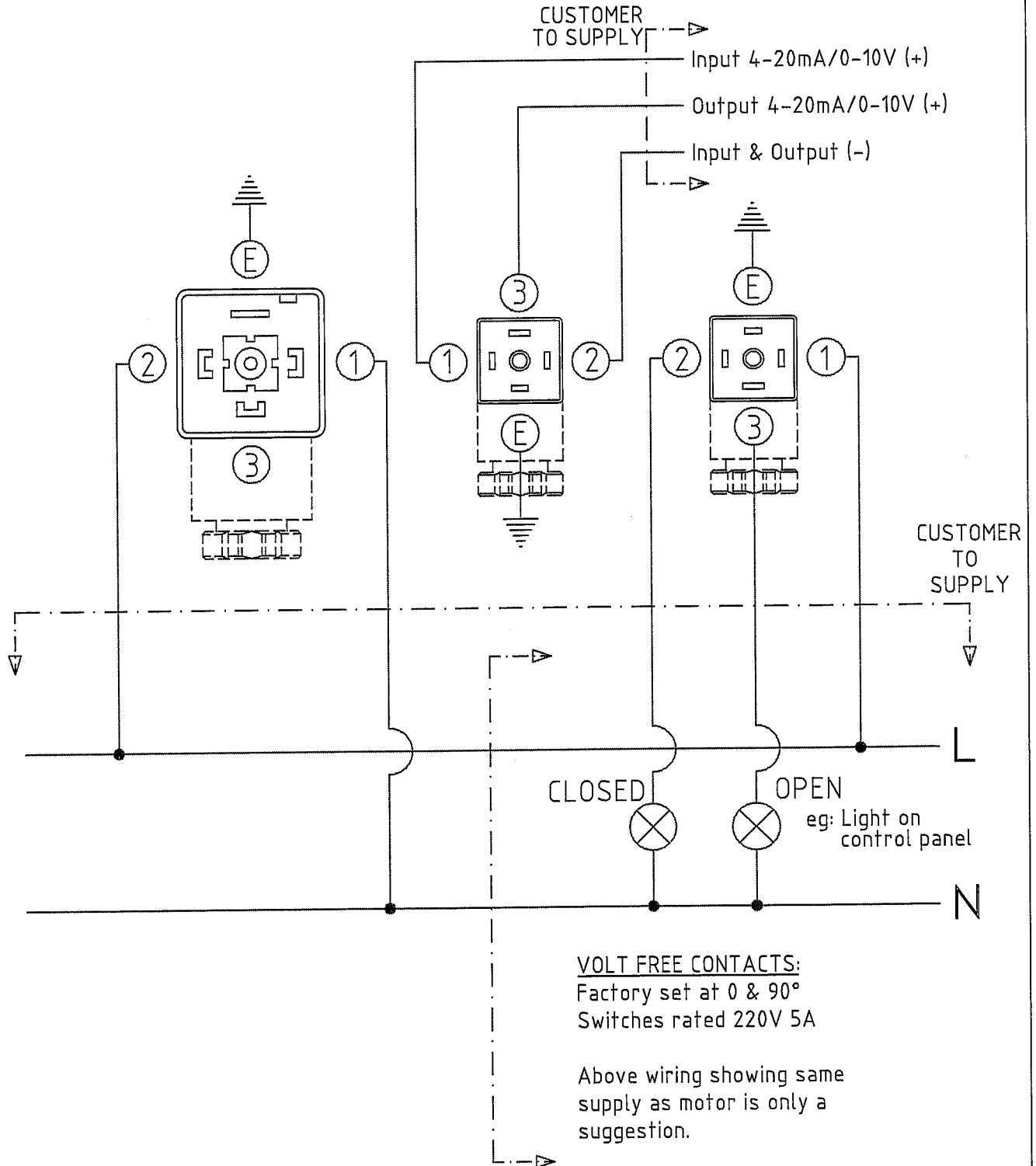

POWER CONNECTION

CONTROL CONNECTION

VOLT FREE CONTACT CONNECTION



NB: READ INSTALLATION, OPERATION & MAINTENANCE INSTRUCTIONS BEFORE CONNECTING.

**AC WIRING DIAGRAM, ALL REVERSIBLE MODELS WITH DPS2000**

<b>J+J</b> ACTUATORS	Drawn By MRG	Chk DC	File Name WACDPS	Scale NTS
	Dwg No. WACDPS	Revision 2	Sheet 1/1	Date 10/12/01

POWER CONNECTION

CONTROL CONNECTION

VOLT FREE CONTACT CONNECTION

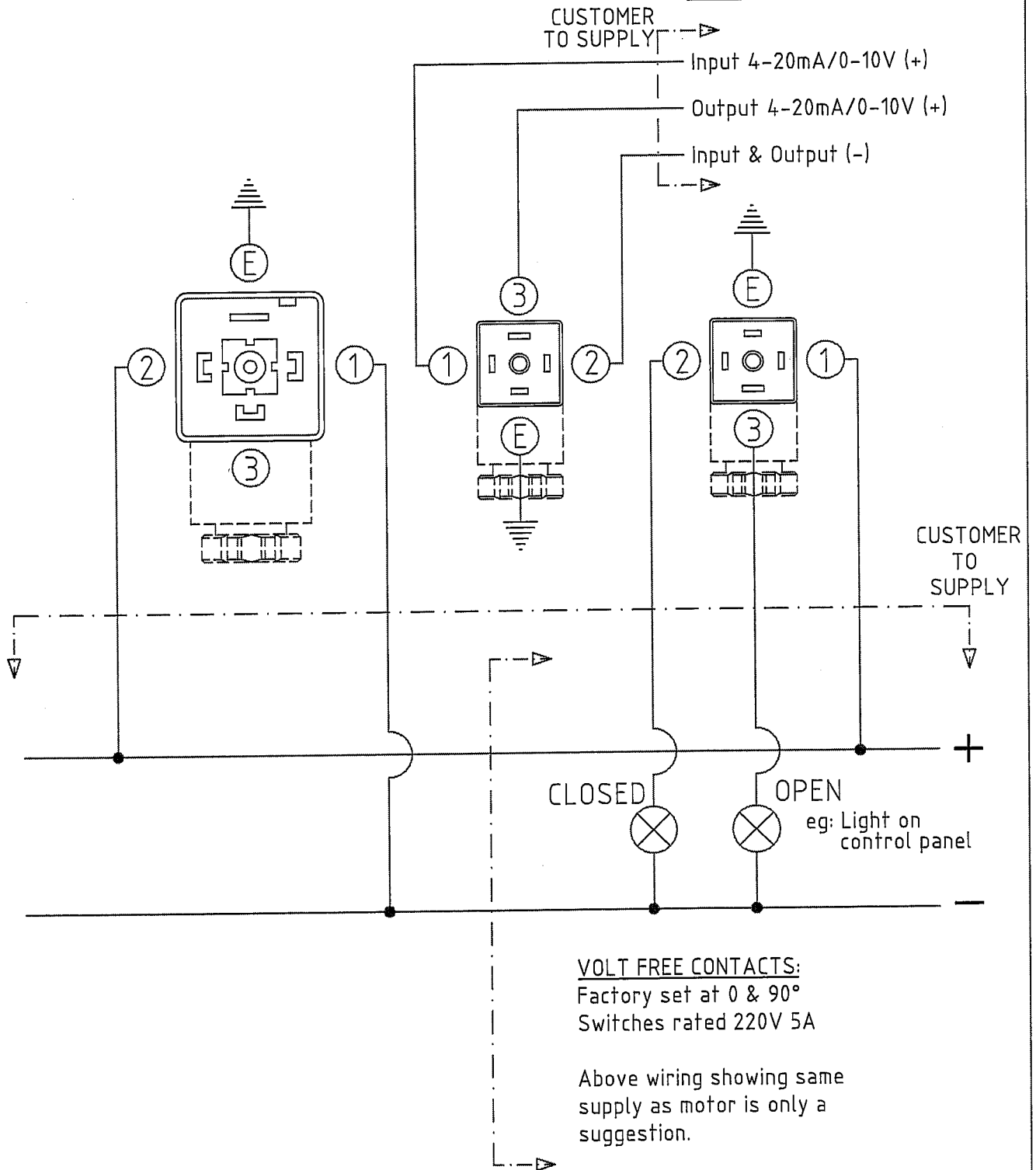

NB: READ INSTALLATION, OPERATION & MAINTENANCE INSTRUCTIONS BEFORE CONNECTING.

**DC WIRING DIAGRAM, ALL REVERSIBLE MODELS WITH DPS2000**

<b>J+J</b> ACTUATORS	Drawn By MRG	Chk DC	File Name WDCDPS	Scale NTS
	Dwg No. WDCDPS	Revision 2	Sheet 1/1	Date 10/12/01

## INSTALLATION, OPERATION & MAINTENANCE INSTRUCTIONS

**Read these instructions fully before attempting to use the actuator as damage caused by non-compliance will invalidate any warranty. If in doubt, ask your supplier BEFORE you connect it.**

### **1 ELECTRICAL CONNECTION**

- 1.1 All J+J actuators have wiring diagrams attached to the side of the actuator on initial supply. Do not remove these diagrams as doing so may invalidate any warranty.
- 1.2 All J+J actuators have Din plug electrical connectors eliminating the need to remove the cover to connect electrically. Removing the cover is not necessary and doing so may invalidate any warranty. Ensure the rubber seal is correctly installed when refitting the plug after wiring to maintain IP65 rating. The Din plugs need to be fitted to maintain its IP65 rating, but take care not to over tighten the securing screws.
- 1.3 **WARNING – DANGER OF SHORT CIRCUITING** – never connect the open and closed pins (except with failsafe models) as this will short circuit the actuator causing irreparable damage and invalidating the warranty. If in doubt, ASK before you connect the power supply.
- 1.4 **WARNING – Overload protection.** We strongly recommend that the actuator is given its own independent fused supply to prevent current from other devices being drawn through the actuator which will cause irreparable damage and invalidate any warranty.

### **2 MANUAL OVERRIDE**

- 2.1 All J+J actuators have a manual override facility, operated by a selector lever, which disengages the motor drive when moved from AUTO to MAN (Manual). The gearbox contains planetary gears and it may be necessary to 'wobble' the selector lever whilst gently moving the manual override handle to ensure the gears disengage and re-engage. When resetting into AUTO – a positive 'click' will be felt when the gears have correctly disengaged/ re-engaged – again, 'wobble' the selector lever if required. Fitted in all reversible models (prefix 'R'), is a safety cut out switch activated by the manual override selector lever, which cuts the power to the motor when in the 'MAN' position.
- 2.2 NEVER remove the selector lever retaining screw as this will allow the operating mechanism to become free and will cause irreparable damage to the actuator's gearbox. Removing this screw will invalidate any warranty.
- 2.3 When in AUTO mode, the manual override operating handle rotates on models U0, R0 and R1 – NEVER restrict this movement or irreparable damage will be caused which will invalidate any warranty. Forcing this override handle to move whilst in 'AUTO', when the actuator is not being operated electrically, will irreparably damage the drive mechanism and invalidate any warranty.
- 2.4 When in MAN mode, avoid rotating the actuator beyond the open and closed logos printed on the top of the actuator. There are no mechanical stops fitted to the actuator (to allow rotations of 120 and 180 degrees) and it is therefore possible to over rotate the actuator. Over rotation will position the internal cams beyond their micro switches, which will result in an abnormal first operation of the actuator when reset into AUTO mode (the actuator will rotate up to 270 degrees until the cam resets in the correct position).
- 2.5 In models where the power is not cut by the manual override selector lever (U0), NEVER leave the actuator in 'MAN' mode if the power supply is controlled by an external source (timer/ control panel etc) as upon receiving a signal to operate, the motor will run continuously as the drive is disengaged, and the motor will burn out, invalidating any warranty.
- 2.6 Open and closed logos are as follows:

OPEN



CLOSED



### **3 APPLICATION / SIZING**

Correctly sized and used within the parameters of the specification of the actuator, over 10 year manufacturing experience shows the J+J actuators will provide trouble free service. NEVER operate the J+J actuators on equipment that can exceed the stated torque as it will cause irreparable damage and invalidate any warranty. Always allow a healthy safety margin when sizing.

### **STANDARD MODELS – POWER OPEN, POWER CLOSE INSTALLATION INSTRUCTIONS**

J+J actuators operate using live electricity and we recommend that only qualified electrical engineers/ electricians be employed to connect the actuators electrically. These user friendly actuators can be fully connected without removing the actuator's cover using the external Din plugs and wiring diagrams affixed to the side of the actuator.

In AC power supplied models, a switch has to be provided by the user to switch the live between open and closed, and in some DC power supplied models, the polarity has to be reversed by components supplied by the user.

## IOM's FOR ALL STANDARD ON/OFF ACTUATORS

<b>J+J</b> ACTUATORS	Drawn By MRG	Chk DC	File Name MSW.JJIOM	Scale NTS
	Dwg No. STD.IOM	Revision 2	Sheet 1/2	Date 04/09/01

- I.1 Check that the voltage being applied matches the voltage shown on the actuator's identification label as damage caused by applying an incorrect voltage will invalidate any warranty.
- I.2 Connect the power supply as per the wiring diagram affixed to the side of the actuator. If in doubt, ASK BEFORE connecting.
- I.3 All J+J actuators are supplied with volt free position confirmation switches (limit switches) which require a separate power supply to operate (rated 240V 5A). The suggested wiring as per the wiring diagram affixed to the side of the actuator shows the same voltage for the actuator being used as the power source for these switches – this is a suggestion only and any standard control voltage can be used (eg: 12 or 24DC).
- I.4 We strongly disapprove of the use of mechanical stops as any physical restriction to the full rotation of the actuator will cause irreparable damage to the gearbox and/or burn out the motor, either invalidating any warranty.
- I.5 Whilst the J+J actuators can be fitted in any orientation subject to ambient/ environmental conditions, we recommend installing the actuator vertically wherever possible. Be aware of applications where elevated temperatures could be present and allow for the possibility of heat rising – in these cases use an extended mounting kit to help dissipate the heat. In applications where ambient conditions (humidity/ temperature) can fluctuate dramatically, we recommend the fitting of internal anti-condensation heaters..
- I.6 If in doubt at any point, ASK before connecting. Common sense and good engineering practice should always prevail.

**OPERATING INSTRUCTIONS – STANDARD POWER OPEN, POWER CLOSE MODELS**

Irreparable damage can easily be caused to J+J actuators through incorrect operation. Ensure the operator is aware of the rotation of the actuator – model U0 is unidirectional, all others are reversing - and exercise extreme caution if, against our recommendations, mechanical stops are to be employed.

These actuators work with the use of cams which operate limit switches, which control the power to the actuator's motor. These cams are factory set at 0 and 90 degrees and whilst they are adjustable, should not normally require any user adjustment.

- O.1 Supply a continuous (not pulse) live signal (either open, or close live) to operate the actuator. The actuator will rotate until the cams operate the micro switch and cut the power to the motor. The actuator will stay in this position until a further continuous live signal is received to send it to its next position. The rest positions will be shown by the open and closed logos, as indicated by a local visual position indicator. NEVER move the set position of this indicator or a false position will be indicated.
- O.2 In the case of mains power failure, the actuator will stay in the position it saw at the moment of power interruption. Should the actuator need to be operated under these circumstances, use the manual override facility, but remember to reset the selector lever in the AUTO position when the movement is completed as outlined earlier.
- O.3 The corrosion resistant housings of the J+J electric actuators are by their nature, not as rust as aluminium housed actuators and should be treated with care. NEVER support or lift an actuated assembly by the actuator or it may break causing irreparable damage and invalidating any warranty.

**MAINTENANCE INSTRUCTIONS**

The J+J electric actuators are designed to be maintenance free, the gearbox is factory lubricated for life and there are no other parts requiring maintenance. Simple external cleaning using soapy water will remove deposits and ensure the open and closed logos remain visible. NEVER pressure wash the actuators as they are not designed to withstand this form of cleaning and irreparable damage caused by pressure washing will invalidate any warranty.

**OPTIONS**

- A FAILSAFE electric actuators. A separate IOM sheet is supplied with failsafe J+J actuators
- B Modulating electric actuators. A separate IOM sheet is supplied with modulating J+J actuators.

**SPECIAL BESPOKE ACTUATORS**

We can supply special configuration actuators in certain circumstances which will be supplied with instructions specific to that build. However, the general IOM's contained in this document will still apply.

**MANUFACTURER'S PRODUCT SUPPORT**

J+J actuators are fully supported in the UK and Ireland and manufacturer's representatives can attend site to assist with 'problems', however a call out charge is made and expenses are recovered if the fault is proven to be 'user generated' due to non adherence to these IOM's. An order number MUST be issued to cover these charges BEFORE they will attend. Should the fault be due to manufacturing or material defects, no charge will be made.

Thank you for purchasing the J+J electric actuator. We trust that you will find them very user friendly and that if installed and operated in accordance with these instructions, you will find they give reliable and trouble free performance. E&OE Rev2 9.01

**IOM's FOR ALL STANDARD ON/OFF ACTUATORS**

<b>J+J</b> ACTUATORS	Drawn By MRG	Chk DC	File Name MSW.JJIOM	Scale NTS
	Dwg No. <b>STD.IOM.</b>		Revision 2	Sheet 2/2
			Date 04/09/01	

**EXTRA INSTRUCTIONS**

**J+J ACTUATOR WITH POSITIONER**

These instructions are to be read in conjunction with the Installation, Operation and Maintenance instructions for STANDARD POWER OPEN/ POWER CLOSE actuators.

**\*\*\* WARNING \*\*\***

**Read these instructions BEFORE you start to handle the actuator AS INCORRECT OPERATION OF THE MANUAL OVERRIDE CAN CAUSE IRREPARABLE DAMAGE WHICH WILL INVALIDATE ANY WARRANTY.**

**INSTALLATION:**

As per standard power open/ power close actuators. We reiterate our dislike of physical travel stops. If you proceed to use physical travel stops, ensure they are set to take effect BEYOND the travel limit of the actuator. If not, the actuator will break as it tries to drive the valve to the next internal cam. Damage of this type will not be covered by our warranty.

All J+J electric actuators are fitted with external Din plugs for electrical connection, eliminating the need to remove the actuator's cover to connect the actuator electrically. Removing the cover, unless directed to do so by J+J (or their distributor), is likely to result in the warranty being invalidated.

**OPERATION:**

Irreparable damage can very easily be caused to the J+J actuators fitted with positioners due to incorrect operation. The positioners are factory set at 0 – 90 degrees and should not, under normal circumstances, require further adjustment. **DO NOT, under any circumstances, attempt to adjust the positioner.** If in any doubt, call your distributor.

- 1 Connect as per the wiring diagram affixed to the side of the actuator. If in any doubt, contact your supplier for wiring details BEFORE you attempt to wire the Din plugs. All connections are made via the external Din plugs and there is no need to remove the actuator cover to connect electrically. Removal of the cover may invalidate any warranty.
- 2 Connect the control signal input (and output, if required) cables to the control Din plug, ensuring that the polarity of the control signal is as per the wiring diagram affixed to the side of the actuator.
- 3 If required, connect the volt free position confirmation cables as per the wiring diagram affixed to the side of the actuator. Note we have shown the supply to the position confirmation plug as the same as the power supply to the actuator – this is a suggestion only and any normal control voltage (eg: 24DC) can be applied to these volt free contacts.
- 4 Ensuring there is no physical restriction to the free rotation of the actuated assembly, apply continuous power to the power Din plug, and a control signal to the control Din plug. Standard control signals are:  
4-20mA positioners:      4mA closed,      12mA mid position      20mA open  
0-10v positioners:      0 V closed,      5 V mid position      10 V open  
If the output signal is being used, check that the output equals the input signal.
- 5 Changing the control signal will cause an equal percentage movement of the actuator, ie: 12mA = 45 degrees movement, or 5 V = 45 degrees movement, for standard 90 degree actuators.  
A local visual position indicator on the top of the actuator will show the actuator's position.  
If the actuator does not respond to control signal changes, check the polarity of the control signal wiring as incorrectly wired control signal plugs will cause incorrect operation of the positioner.
- 6 For emergency use, a manual override is supplied, operated by the use of the MAN/ AUTO selector lever fitted to the side of the actuator. Operation of the manual override is as per the standard instructions, but extreme caution must be used when operating the 'modulating' actuator in 'MAN' as incorrect use due to over rotation WILL damage the positioner and WILL invalidate the warranty;

**EXTRA INSTRUCTIONS – DPS2000 POSITIONER**

<b>J+J</b> ACTUATORS	Drawn By MRG	Chk DC	File Name MSW.JJIOMP	Scale NTS
	Dwg No. IOM.DPS2000	Revision 2	Sheet 1/2	Date 04/09/01

**\*\*\*\*\* WARNING – USE OF MANUAL OVERRIDE \*\*\*\*\***

An internally fitted gearwheel is fixed to the actuator's output shaft – this gear is the physical link from the positioner's circuitry to the actual output shaft position, and is used to compare the digital input position with the actual shaft position. This gear is connected to an internally fitted feedback potentiometer which has a **MAXIMUM ROTATION OF 110 DEGREES**. Rotation beyond this will irreparably damage the potentiometer, causing failure of the positioner, and invalidate any warranty.

**IT IS ABSOLUTELY CRITICAL THEREFORE, NOT TO ROTATE THE ACTUATOR BEYOND THE 0° TO 90° LOGOS MARKED ON THE TOP OF THE ACTUATOR AS SHOWN BELOW**

CLOSED (0°)



OPEN (90°)



**MAINTENANCE:**

As per the standard Installation, Operation and Maintenance Instructions.

**TROUBLESHOOTING:**

For information, every ISO9000 manufactured J+J actuator is fully function tested at the factory prior to being distributed, and are supplied in purpose-made polystyrene protective cartons to protect against transit damage.

Fault: The actuator does not respond to any control voltage supplied

- Check the following:
- a. Power supply voltage matches actuator nameplate/ label
  - b. Control signal voltage matches actuator nameplate/ label
  - c. Din plugs are correctly wired, with correct polarity, and fitted to din plug base
  - d. Actuator is in 'AUTO' (power cut to motor in 'MAN')

(In all reversible models, a safety cut out switch operated by the manual override selector lever, cuts power to the motor. If you have operated the actuator by use of the manual override and cannot restart the actuator, check that the manual override selector lever has been reset in the 'AUTO' position.)

Fault: The actuator only moves a few degrees when given maximum/minimum control signals

- Check the following:
- a. The polarity of the control signal din plug cables
  - b. The actuator may have been over rotated (see above warnings)

**MANUFACTURER'S PRODUCT SUPPORT**

J+J actuators are fully supported in the UK and Ireland and manufacturer's representatives can attend site to assist with 'problems', however a call out charge is made and expenses are recovered if the fault is proven to be 'user generated' due to non adherence to these IOM's. An order number MUST be issued to cover these charges BEFORE they will attend. Should the fault be due to manufacturing or material defects, no charge will be made. Should you damage the positioner by over rotating the actuator whilst in manual override, it *may* be possible to have the positioner re-calibrated by returning it to the manufacturer. All costs incurred are chargeable.

Thank you for ordering the J+J reversible electric actuator with positioner. Correctly applied, installed, connected and operated in accordance with these instructions, your J+J actuator with positioner should give you reliable and trouble free performance.

E&OE Rev 2 9.01

**EXTRA INSTRUCTIONS – DPS2000 POSITIONER**

<b>J+J</b> ACTUATORS	Drawn By MRG	Chk DC	File Name MSW.JJIOMP	Scale NTS
	Dwg No. IOM.DPS2000	Revision 2	Sheet 2/2	Date 04/09/01